

Leadership Excellence

Be All You Can Be

2026 USACC JROTC National Raider Challenge Welcome Packet



****All Times Are Eastern Time Zone
Unless Otherwise Specified**



Contents

*Be All You Can Be*

- Competition Overview
 - Concept of the Operation
- Reception Operations
 - Instructions to Teams
 - Reception Center Layout
 - Required Check-in Documents
 - Instructions to Parents and Spectators
- Competition Timeline
 - Family Events to Attend
- 1 Mile Track Event Site
 - Events
 - Task/Condition/Standards
- Ultimate Raider
 - Event
 - Task/Condition/Standard
- Event Scoring
 - Penalties
 - Scoring Concept
- Scoring Protest Flowchart
- Demonstrations, Static Displays, and College Row
 - Demonstrations
 - Static Displays
 - College Row
- Ceremony/Awards Concept
 - Opening Ceremony
 - Challenge Division Awards Ceremony
 - Masters and All-Service Awards Ceremony
- Logistical Support Overlay
 - Barracks Billeting Layout by Brigade
 - 1 Mile Track Concept of Support
- Medical Support Overlay
 - Concept of Medical Support
 - Responder Sequence
 - 1 Mile Track Medical Asset Layout
 - Available Competition EMT Assets
 - What's Available to Teams
 - Medical Facilities
- Hold Harmless Waiver
- Media Release Waiver
- Coaches Code of Conduct
- Cadet Packing List

National Raider Challenge Competition

Competition Overview



Leaders for Life



National Raider Challenge Overview



Be All You Can Be

Event Overview

A world class event showcasing the Fort Knox Community and Army Enterprise to high school JROTC Cadets, families, and spectators. Attendees are exposed daily to National recruiting assets and capability displays. The robust display tells the Army Story to attending JROTC Cadets, coaches, and family throughout the weekend and presents a variety of opportunities to serve. USACC and USAREC join to maximize opportunities during the event, supporting the FY26 recruiting effort.

Competing Team Division

**Army Challenge
(5 events)**

Physical Team Test, Cross Country Rescue,
Gauntlet, 5K Run, & Rope Bridge

**All-Service
(6 Events)**

All above + Ultimate Raider

**Army Master
(7 Events)**

All above + Battle Fit Challenge (1-1-1)

Three Team Divisions:

- Army Challenge
- Army Master
- All-Service
- Ultimate Raider team (Buddy teams of the top 5 teams in each sub-category of Master/All-Service (M, F, & MXD))
- Each team category must complete 5x Independent Lanes (Obstacle Courses, 5K Run, Battle Fit Challenge & Rope Bridge)
- Team compositions can be male, female & mixed gender
- Teams consist of a maximum 14 persons, only 10 persons will participate in each event
- Schools enter as many teams in each category as they have participants to fill the teams. Participants can only be on one team
- Schools that trophied in the Challenge Division in previous year are no longer eligible to compete in the Challenge Division (Registration Screening)

Events Summary: All teams compete in five (5) events (Physical Team Test, Cross Country Rescue, Gauntlet, 5K run, and Rope Bridge) Masters and All Service Division will also conduct the Ultimate Raider. Master's Division is the only division required to compete in the Battle Fit Challenge. This event is optional for Cadets in the other two divisions.

Concept of the Operation

Be All You Can Be

Mission: USACC conducts the 3rd Annual National Raider Challenge Competition for execution from 16-19 APR 26 at Fort Knox, KY in order to facilitate a world-class event for JROTC Cadet Raider Challenge teams.

Commander's Intent:

- 1) Execute an event that is enduring and expandable.
- 2) Showcase the Fort Knox Army experience and the Army to Cadets, parents, and spectators.

Key Tasks:

- 1) Establish a safe and friendly environment for Cadets and families.
- 2) Tell the Army story (Demonstrations and Static Displays).
- 3) Ensure reliable communication between event sites and grading cell.

End State:

USACC and Fort Knox successfully host the 3rd Annual National Raider Challenge Competition with limited interruption from weather and all JROTC schools, Cadets and families return to their districts to spread the Army story to local populations.

PH I: PLANNING and PREPARATION

Purpose: Resource and Synchronize Competition.

Begins: Upon Receipt of the Order

Ends: Completion of Registration

Critical to Phase: Course Layout, School Registration, Obstacle Construction, T2T, ID Event Support Requirements, and Finalize Sync Matrix and LOG Support Matrix.

PH II: CERTIFICATION

Purpose: Acquire Resources and Validate Competition Sync Matrix.

Begins: Completion on Registration

Ends: Opening Ceremony

Critical to Phase: RXLs, Event Site Setup, RSOI (Teams and Cadre), and Competition Validation.

PH III: EXECUTION

Purpose: Provide World Class Event for JROTC Cadets

Begins: Opening Ceremony

Ends: Final Awards Ceremony

Critical to Phase: Demonstrations, Static Displays, Recruiting, Messaging, Event Division Execution.

PH IV: RECOVERY

Purpose: Capture Lessons Learned to Facilitate 2026 Competition Execution

Begins: Final Awards Ceremony

Ends: Completion of the AAR
Critical to Phase: Event Site Recovery, Barracks Closeout, Messaging, and AAR.





Leadership Excellence

Be All You Can Be

National Raider Challenge Competition

Reception Operations



Leaders for Life



Instructions to Teams

Be All You Can Be

- Prior to arrival, please register all parties over the age of 17, to include bus driver and buses, with the FT Knox Directorate of Emergency Services.

[2026 National Raider Challenge Installation Access Registration](#)



- All pre-registered bus traffic will enter Fort Knox through the **Wilson Gate**.
- Park bus as far forward as possible in adjacent lot (towards 15th Cavalry Rd).
- Coaches and team Captain only in the reception center. Teams will remain on the bus.
- Have a by-name team roster ready for check-in and accountability procedures.
- After visiting your three stations at the reception center, please move to your bus and transit to your assigned barracks (Strip map provided by your brigade).
- A brigade representative will meet you in the designated parking lot and escort you to your assigned quarters.
- Buses may be required to relocate from this parking lot to ensure flow of traffic. Ensure all items are off the bus upon arrival.

Team Reception Center

Be All You Can Be

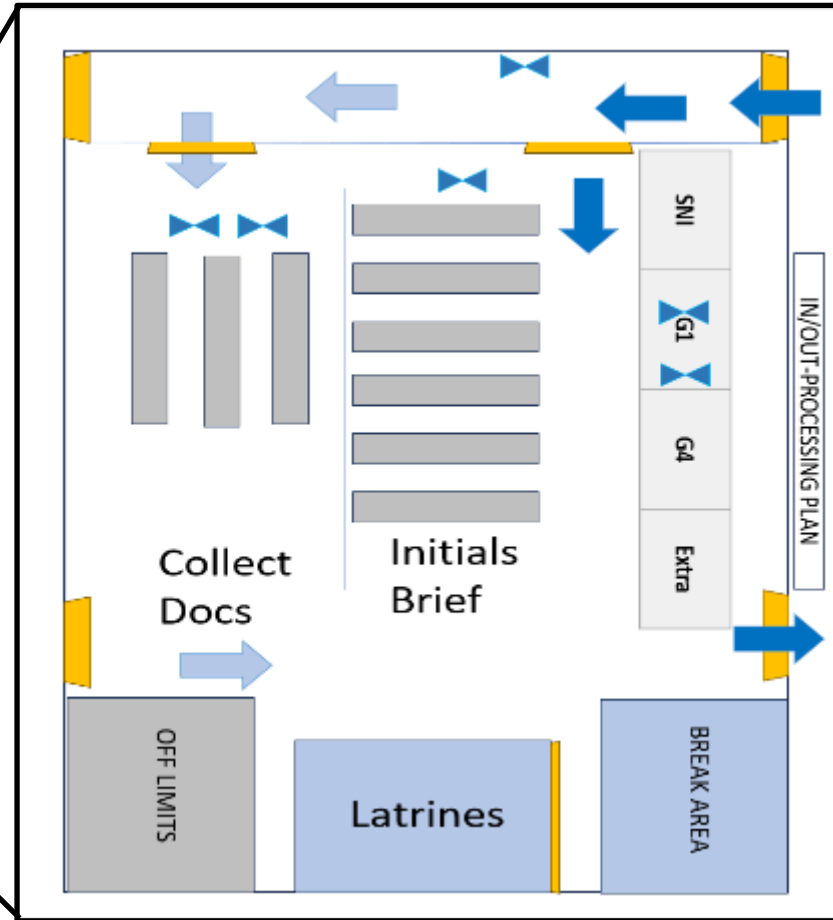

In-Processing:

All Coaches and Cadre will enter Bldg 5942 and visit the SNI table to grab their registration packet. Once complete, Coaches and Cadre will then move to G1 to submit an emergency data sheet for all the Cadets and receive the NRC Missing Person Guidance. Coaches/Cadre will proceed to G4 and remaining stations. **At no time with JROTC Cadets be allowed to enter the RSOI Building.**

Out-Processing:

Coaches/Cadre will enter Bldg 5942 to visit the G4 table for barracks clearance, then proceed to the G1 table, state their school. G1 will pull their packet and the Coach/Cadre will sign the Out-processing portion of the checklist and depart the building.



Leadership Excellence



Be All You Can Be

Cadre and Coaches with Cadets can report any status updates (i.e. Trip to Hospital, Sick Call, Missing, Absence Unknown, etc.) by downloading the **Signal App** and joining the Group:

USACC NRC RSOI Duty Status



Or Go to website on your mobile device:

<https://signal.group/#CjQKIHI8NNPX3Aae-2-8t4eGZCAibq2Uh3RILykcNMPw6gv4EhDMWdeMjUa7AyLAXuYYfhNa>

Text Requirements:

For Cadre:

- Rank, First and Last Name
- Brigade #
- Status (Left for Hospital or Went to Sick Call, etc.)
- Cadre are required to text an updated status (i.e. SFC John Smith has returned to duty, etc.)

Text Requirements:

For Coaches with Cadets:

- Coach full Name
- Brigade #/JROTC School
- Gender of Cadet
- Status (i.e. *Left for Off post Hospital, etc*)
- Once the Cadet is complete at Hospital, the Coach should text an update status (i.e. Cadet full name has returned to duty, etc.)

Cadre and Coaches can use the **Signal App** for further communications and RSOI Information by joining the Group below:

USACC NRC – General Chat Channel



Or Go to website on your mobile device:

https://signal.group/#CjQKIO6kco8YidpMUTtetFoVtKqccu1rWxCDIq5gTvF5wuFEhBqYDpUQAc_sDjhSTs8r_gA

**FOR ALL LIFE-THREATENING
EMERGENCIES DIAL : 911**

**TOC MAIN #: 270-832-0489
270-832-0381**



Team Check-in Checklist



Be All You Can Be

Team Check-in Checklist	
	Hold Harmless Waivers (G1)
	Media Release Waivers (PAO)
	Emergency Data Sheet for Each Cadet (G1)
	Clear Group Photo of All Attending Cadets (G1)
	Signed Code of Conduct (All Instructors) (JROTC)
	Completed Billeting Registration Sheet (provided at RSOI)
	Confirmation of Division Registration (JROTC)
	Confirmation of Required Chaperones



Personnel Checklist Verification

Be All You Can Be

School Name and BDE: _____

- Coach must provide all Coach and Cadet information (This includes Cadets that are not participating.)
- Have all Cadets fill out the Emergency Data Sheet*
- Take a Clear Group Photo of all Cadets**
- Coach has verified and completed all above tasks:**

Print Full Name, Rank (if applicable)

Signature Date: _____

Cell #

Out-Processing Checklist

(to be completed on Final Out)

Coach has accounted for all Cadets and is signing out:

Print Full Name, Rank (if applicable)

Signature Date: _____

USACC CLEAR

*Return this checklist and Data Sheet to G-1 Cell during Check in.
 **One Cadre/Coach will take a clear picture on their mobile device of their JROTC team in case of emergencies. This will remain with the Coach for reference.



Emergency Data Worksheet



Be All You Can Be

CADET Last Name:		CADET First Name:		CADET Middle:		AGE:	
JROTC HS Name:							
USACC Brigade #:			Gender:		Date of Birth:		Place of Birth:
Brigade Commander:			Brigade JROTC POC:				
Blood Type:		Ethnicity:		Last 4 SSN:		Height/Weight:	
Eye Color:			Hair Color:				
Home Address:							
CADET Cell Phone:							
History Of:		Heat Injury:			Cold Injury:		
<u>PARENT (GUARDIAN) INFORMATION:</u>							
1) First, Last Name:				Relationship:			
Email Address:							
Home Address:							
Phone Number:							
Military Service (circle one): Active Duty? Y or N Reserve/National Guard? Y or N Retired Military? Y or N							
2) First, Last Name:				Relationship:			
Email Address:							
Home Address:							
Phone Number:							
Military Service (circle one): Active Duty? Y or N Reserve/National Guard? Y or N Retired Military? Y or N							
3) First, Last Name:				Relationship:			
Email Address:							
Home Address:							
Phone Number:							
Military Service (circle one): Active Duty? Y or N Reserve/National Guard? Y or N Retired Military? Y or N							
<u>COACH/CADRE INFORMATION:</u>							
1) First, Last Name:				Relationship:			
Email Address:							
School Address:							
Phone Number:							
2) First, Last Name:				Relationship:			
Email Address:							
School Address:							
Phone Number:							
3) First, Last Name:				Relationship:			
Email Address:							
School Address:							
Phone Number:							
<u>REMARKS/NOTES:</u>							

Flowchart for Missing Cadet

Be All You Can Be

ABSENT AND MISSING PERSONS RESPONSE PLAN SOP

Absent Cadet Flowchart

Legend

Cadre/Coach
G3 TOC
DES
HRC
BDE CMD
★ Decision

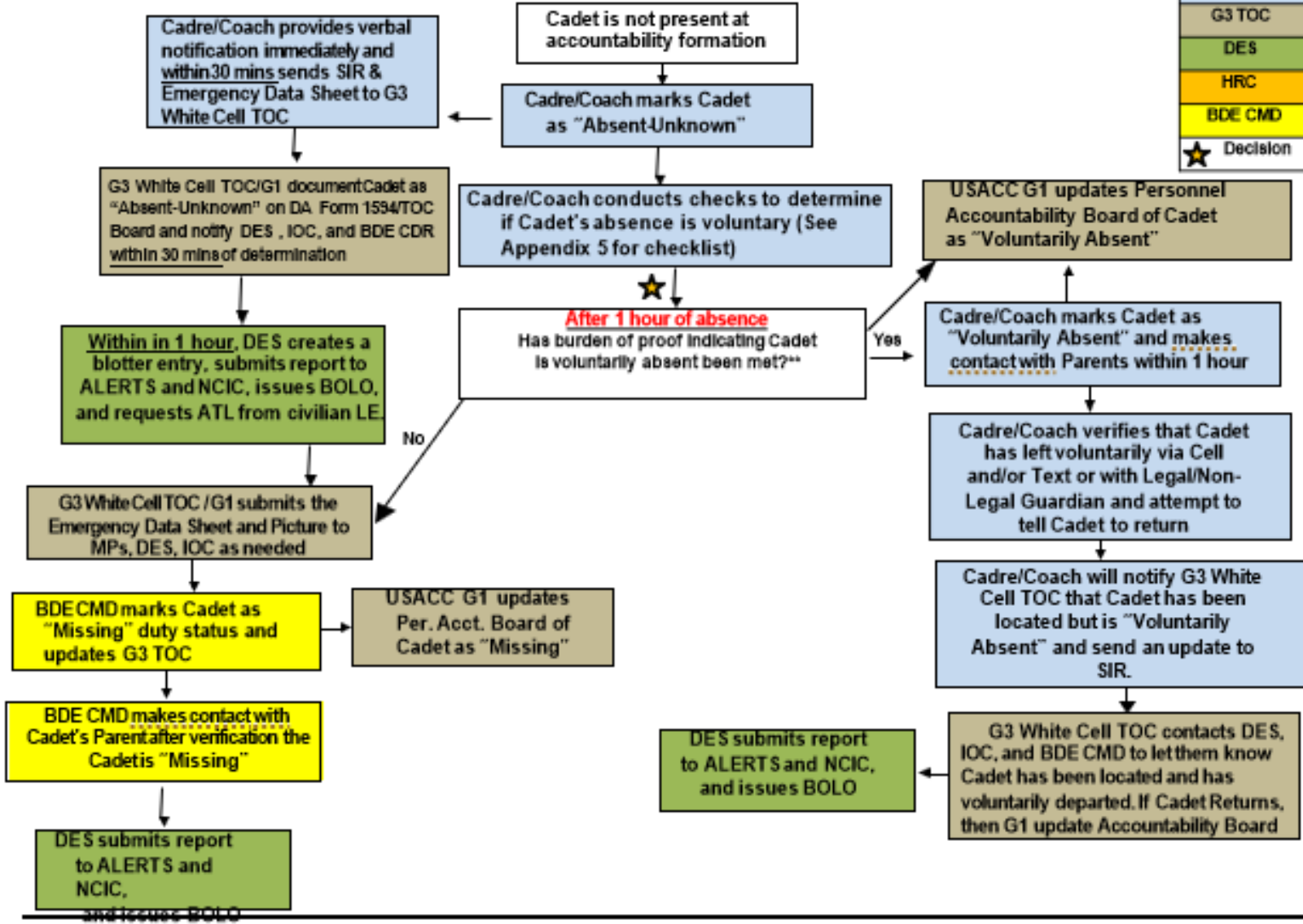

Fort Knox Missing Personnel Guide



Be All You Can Be

Operations Guide to a Absent and Missing Persons on Fort Knox during a JROTC Event

I. For Absent and Missing Cadets

- 1) Prior to arrival to Fort Knox, Cadre/Coaches are to ensure that each JROTC Cadet fill out the Enclosure 1: Emergency Data Sheet. In an event of emergency, Cadre Coaches will send this Emergency Data sheet along with a copy of a photo and CCIR of the Cadet to G3 TOC within 30 mins of the Cadet being missing.
- 2) Cadre/Coaches/G3 TOC will review the "Absent Cadet Flowchart" and Battle Drills in the event of a death or missing JROTC Cadet and initiate a CCIR.
- 3) Cadre/Coaches will used Enclosure 2 – (Cadre/Coach Checklist in Searching for a Missing JROTC Cadet) to start the initial search of a missing JROTC Cadet and submit a copy to the G3 upon completion.
- 4) Within 1 hour of the missing Cadet, the Cadre/Coach will notify G3 TOC giving a reasonable determination (if applicable) whether the Cadet is Missing or has voluntarily departed without permission.
- 5) See flow chart for the steps to take after 1 hour.
- 6) Cadre/Coach will call G3 White Cell TOC @ _____, their lead Brigade JROTC Chief, and their respective Brigade Commander:

II. For a Missing Adult – Not a Soldier or Civil Servant

- 1) Refer to the Fort Knox SOP on Absent and Missing Person Response Plan, ANNEX D (Missing Adult-Not a Soldier or Civil Servant).

III. For a Missing Civil Servant

- 1) Refer to the Fort Knox SOP on Absent and Missing Person Response Plan, ANNEX B (Missing Civil Servant) and Appendix 1 (Checklist for Missing Civil Servant) to ANNEX B (Missing Civil Servant for procedures on missing DoD Civilians).

IV. For a Missing Soldier

- 1) Refer to the Fort Knox SOP on Absent and Missing Person Response Plan, See Appendix 2 (Flowchart #1) to ANNEX A (Missing Soldier) and Appendix 3 (Flowchart #2) to ANNEX A (Missing Soldier).
- 2) Examples for Investigation Officer (IO) letters are located under Appendix 4 (Sample 15-6 Investigation Officer Appointment Memo) to Annex A.
- 3) Appendix 5 gives examples of DA Form 4187s for duty status changes. (This HR Action is now done in IPPS-A as a Duty Status HR PAR to change the duty status of a Soldier. An HR Professional in G1/S1 will conduct this task.)
- 4) Annex A (Missing Soldier) outlines the steps taken by the Soldier's unit, the unit PAO, DES, and IOC if the Soldier is AUN, Missing or AWOL.

JROTC Missing Cadet Checklist



Cadre/Coach Checklist for a Missing JROTC Cadet

Be All You Can Be

Name of Cadre/Coach: _____

Date/Time: _____

_____	Has an initial assessment been conducted to determine if the cadet's absence is involuntary? (Missing person or Absent Unknown)
_____	Has a cadre member conducted a headcount and checked all exits, vehicles, empty rooms, and offices?
_____	Has a cadre member verified the name of the missing cadet?
_____	Has a cadre member/supervisor notified the MP's about the situation? What time? Last known location? Last time cadre members saw the cadet. MP Time: Last know location: Last time seen/date: _____ Video? Y or N
_____	Were the cadet's parents notified?
_____	Where did the cadre member(s) check for the cadet? Locations below:
_____	(Once cadet is located) When and where was the cadet located? When: Where:
_____	(Once cadet is located) Where the MP's notified? They have to be notified in order for the cadet to be taken out of NCIC. Did they conduct a Health and Welfare check?

Instructions to Parents and Spectators

Be All You Can Be

- There will be no formal reception center for visiting parents and spectators upon arrival to Fort Knox.
- Prior to arrival, please register all parties over the age of 17, to include bus driver and bus, with the FT Knox Directorate of Emergency Services.

[2026 National Raider Challenge Installation Access Registration](#)



- Pre-registration will significantly reduce backlogs and congestion at the gates.
- For those that don't pre-register all members prior to arrival, you will be required to register at the Fort Knox Visitor Center (near the Chaffee Gate).

Arriving by RV

- Arriving RVs will enter through the Wilson gate due to height restrictions of other gate entrance routes. **Height restriction is 13' 11" at the gate.**

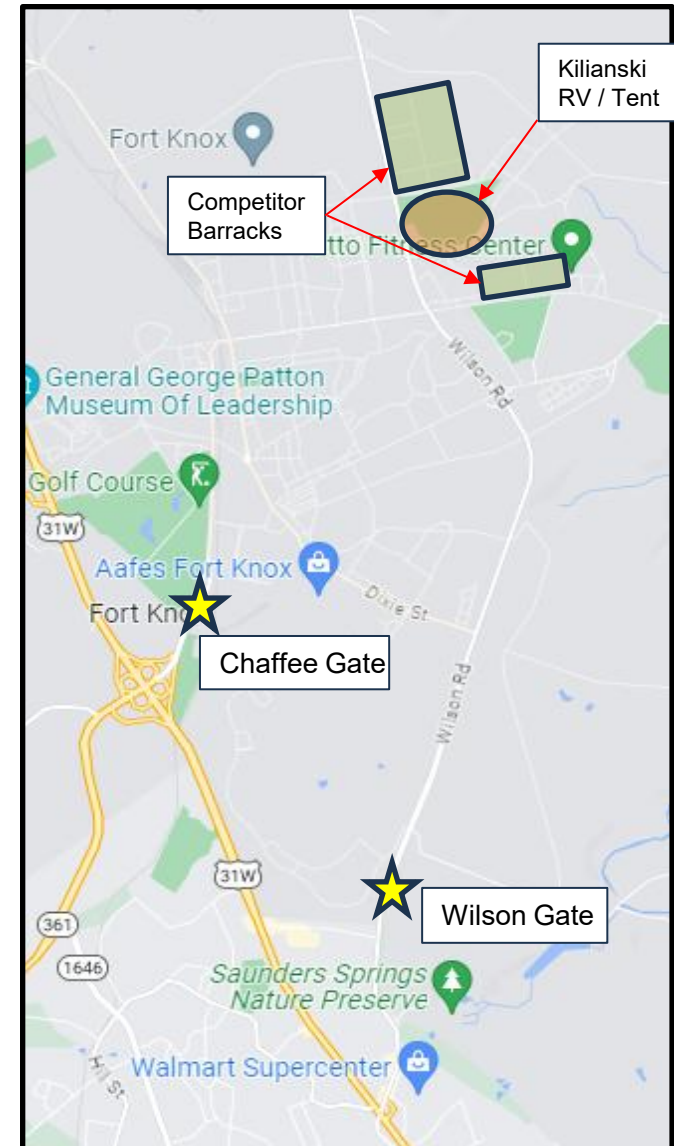

Updated: 3-Apr-26 11:43

One ROTC



Leadership Excellence

Be All You Can Be

National Raider Challenge Competition

Competition Timeline



Leaders for Life



2026 NRC Execution Timeline



Be All You Can Be

16-20 MAR		16 MAR – 12 APR		13 APR		14 APR		Thursday 16 APR																				
		Lane/ Site set-up		Competition and Ceremony RXLs		CG and CSM Event Certification		1200	1230	1300	1330	1400	1430	1500	1530	1600	1630	1700	1730	1800	1830	1900						
GBR On-Boarding		Lane/ Site set-up		Competition and Ceremony RXLs		CG and CSM Event Certification		Challenge and All-Service Optional Battle Fit Challenge										As You Were Band		- Opening Ceremony (1 Mile Track)		Parade of Cadets		Fireworks				
								Static Displays																				
		0700	0730	0800	0830	0900	0930	1000	1030	1100	1130	1200	1230	1300	1330	1400	1430	1500	1530	1600	1630	1700	1730	1800	1830	1900		
Friday 17 APR	LANE	<ul style="list-style-type: none"> Physical Team Test <ul style="list-style-type: none"> Cross Country Rescue Gauntlet (Obstacle Course) Rope Bridge Team 5k Run 										Army Challenge Division All events occur simultaneously												LANE				
		Masters Division Battle Fit Challenge																										
		Static Displays																										
Saturday 18 APR	INFILL	<ul style="list-style-type: none"> Physical Team Test Cross Country Rescue Gauntlet (Obstacle Course) Rope Bridge Team 5k Run 										- Black Knights Jump (1 Mile Track)		- Challenge Division Awards Ceremony (1 Mile Track)		Army Masters and All-Service Divisions All events occur simultaneously												EXFILL
		Static Displays																										
Sunday 19 APR	Ultimate Raider Top 5 Masters Teams Top 3 All-Service Teams (Male, Female & MXD)				- Knock Out a Bunker (1-Mile Track)		- Black Knights Jump (1-Mile Track)		- Masters and All-Service Divisions Awards Ceremony (1-Mile Track)		Brigade Team Departure																	
	Barracks Closeout/Campsite Teardown				JROTC Team Departure																							
Monday 20 APR	GBR Departure				Brigade Trail Departure																							



2026 NRC Family Events



Be All You Can Be

Thursday, 16 APR – 1-Mile Track

- Live Performance From The Army As you were Band (5:00-6:00 pm)
- Opening Ceremony (6:00 pm) - Teams Arriving NLT 3 pm Will Be Introduced At The “Parade Of Cadets” Just Like The Olympics.
- JROTC T-shirt Giveaways Throughout

Friday, 17 APR – 1-Mile Track

- UH-60 Blackhawk Flyover (various)
- Army Static Displays (8:00 am – 5:00 pm)
- Army Fitness Trailer – All Day
- Decide To Lead Trailer (VR Exhibit) All Day
- Cadet Command ROTC College Row (8:00 am – 5:00 pm)
- Military Working Dog Demonstration (2:00 pm)
- Food Truck Festival Supporting The Competition Throughout The Day

Saturday, 18 APR – 1-Mile Track

- UH-60 Blackhawk Flyover (various)
- Army Static Displays (8:00 am – 5:00 pm)
- Army Fitness Trailer – All Day
- Decide To Lead Trailer (VR Exhibit) All Day
- Cadet Command ROTC College Row (8:00 am – 5:00 pm)
- USMA Parachute Demonstration (11:55 am)
- Challenge Division Award Ceremony (12:00 pm)
- Military Working Dog Demonstration (2:00 pm)
- Food Truck Festival Supporting The Competition Throughout The Day

Sunday, 19 APR – 1-Mile Track

- Air Assault/Knock Out A Bunker Demonstration (11:00 am)
- USMA Parachute Demonstration (11:55 am)
- All-service And Masters Division Award Ceremony (12:00 pm)
- Team Departure (3:00 pm)



Leadership Excellence

Be All You Can Be

National Raider Challenge Competition

Event Concepts



Leaders for Life



Raider Events Macro

Be All You Can Be

- Raider TOC**
 - JROTC Classroom
 - OIC: MAJ Kuenker (G33)
 - A/OIC: MAJ Williams (G33)
- Demonstrations**
 - USMA Parachute Demonstration
 - 34th MPs
- Barracks**
 - 22 Barracks Buildings in the Disney and 6500 complex
- Static Displays**
 - USAREC
 - MO, MS, KY ARNG
 - 75th Ranger Regiment
 - US/Foreign Weapons
 - Diesel Dog
 - College Row
- Vending**
 - Food Trucks
 - AAFES Mini Store
- RV Parking**
 - Family RV Parking
- POV Parking**
 - Parking support for families staying off post at hotel/camping sites

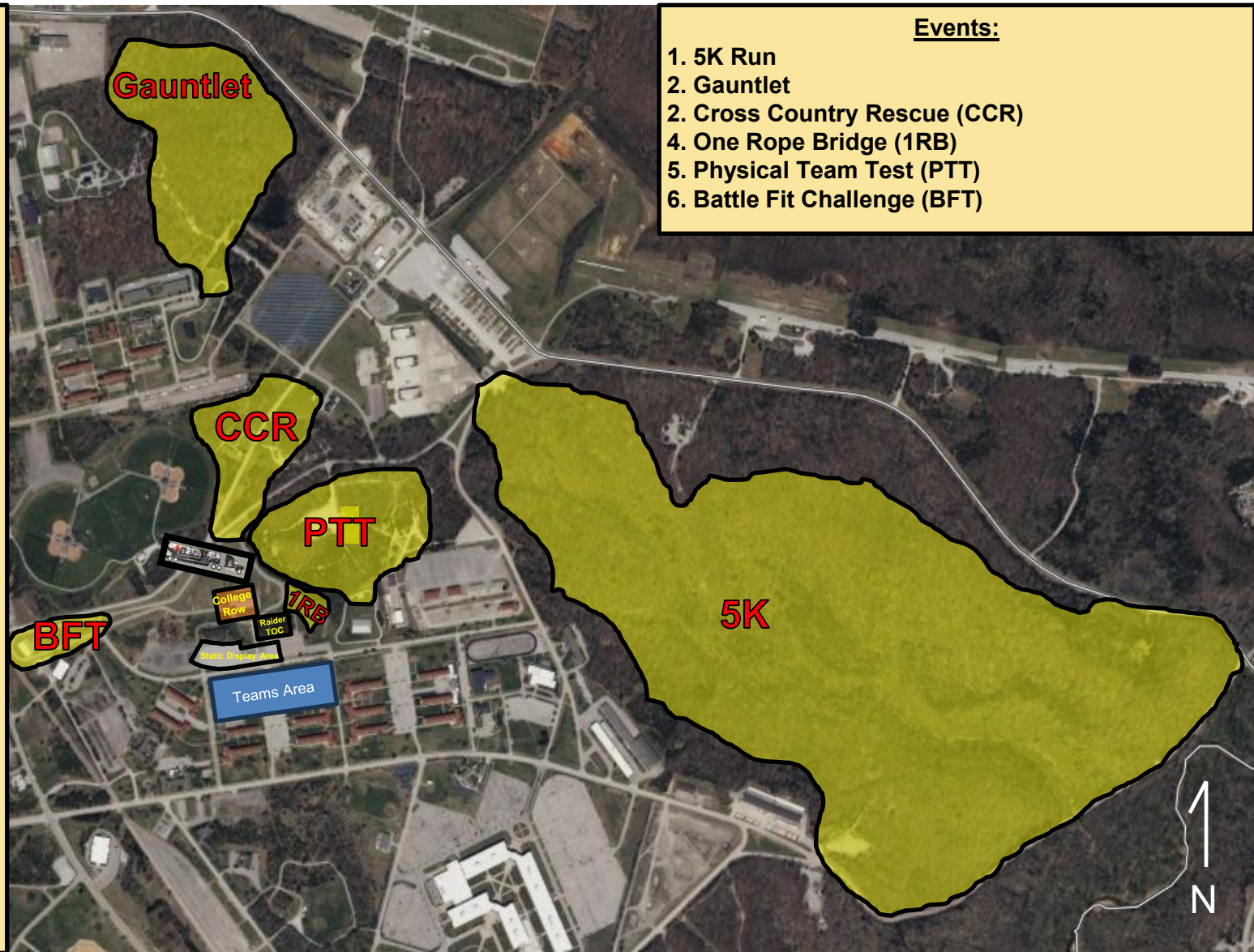

- Events:**
- 5K Run
 - Gauntlet
 - Cross Country Rescue (CCR)
 - One Rope Bridge (1RB)
 - Physical Team Test (PTT)
 - Battle Fit Challenge (BFT)



1 Mile Track Macro

Demonstrations

- MFF Demo Team
- Knock out a Bunker
- 34th MPs (MWD)
- 105mm Cannons

Barracks

- 22 Barracks Buildings in the Disney and 6500 complex

Static Displays

- USAREC Trailers
- KY ARNG
- 75th Ranger Regiment
- NGB AVN Assets
- College Row

Vending

- Food Trucks
- AAFES Mini Store

RV Parking

- Family RV Parking

POV Parking

- Parking support for families staying off post at hotel/camping sites

Team Areas

- Teams' canopies, staging, and recovery area

Events

- Cross Country Rescue
- Physical Team Test
- Battle Fit Challenge
- ORB
- 5K
- Gauntlet





Battle Fit Challenge (8th BDE)

Who : 8th Brigade SROTC
What: Battle Fit Challenge
Where: Fort Knox, KY
When: 16-17 APR 2026
OIC: TBD

Key Tasks:

1. Conduct 1 Min of Push-Ups
2. Conduct 1 Min of Sit-Ups
3. Conduct 1 Mile Run

Concept:
 The Battle Fit Challenge will be conducted with 10 lanes. One grader and one timekeeper per lane.

Event Sequence:

1. Competitors will execute as a Team and will remain in that team throughout the event.
2. First event will be individual 1 minute max push-up event. Upon completion, competitors will move to sit-up bars. Upon completion, competitors will have 10-minute rest period before starting the modified sit-ups.
3. Second event will be individual 1 minute max modified sit-ups. Upon completion, competitors will have 10-minute rest period before beginning third and final event.
4. Third event will be 1-mile run. Teams will begin at the start point and run two laps around the .5-mile course.
5. The flow will be managed by the Event OIC. When all competitors have completed the 3x events, score sheets will be tallied by the event NCOIC.

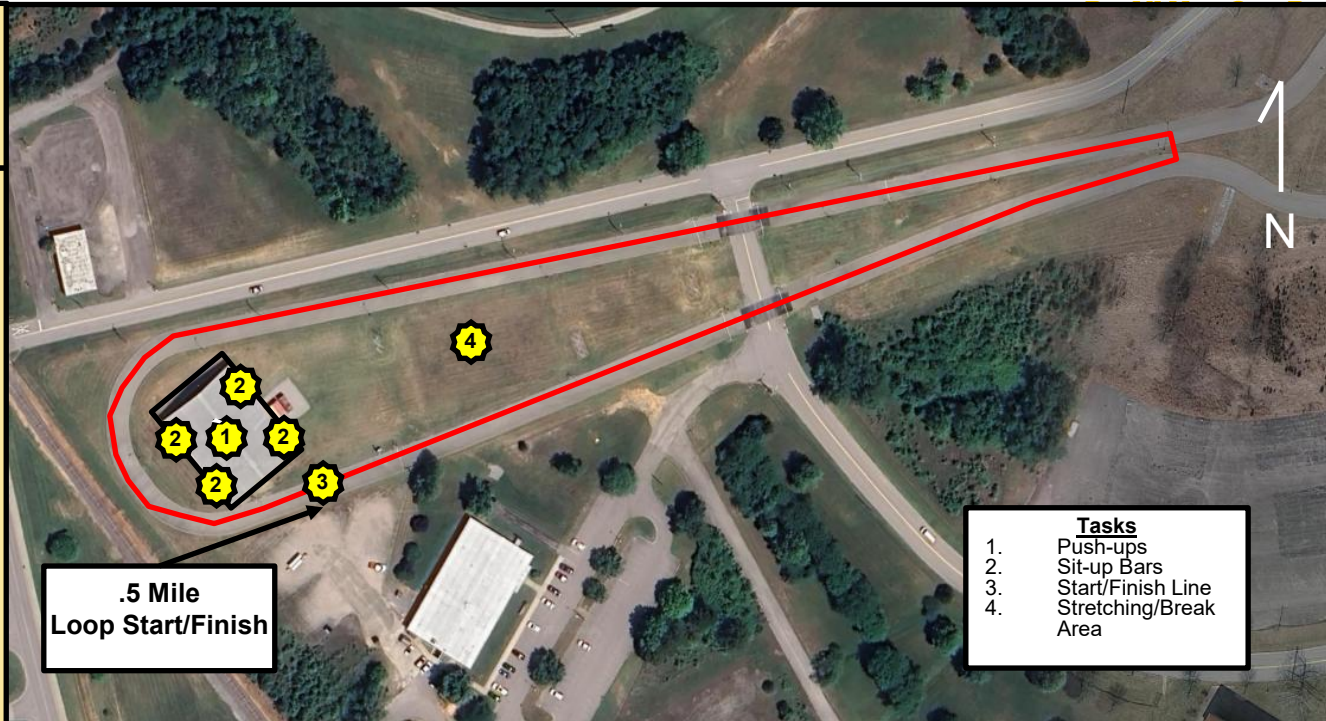

.5 Mile Loop Start/Finish

- Tasks**
1. Push-ups
 2. Sit-up Bars
 3. Start/Finish Line
 4. Stretching/Break Area

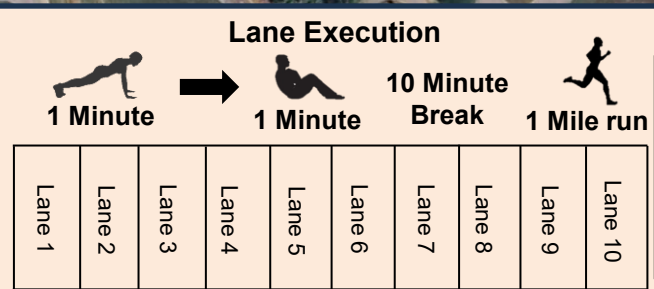

-Each team will have the same grader/timekeeper throughout the event
 -Each team will execute the push-up/sit-up event in the same order (first on push-up will be first on sit-up)
 -10-minute break after completion of sit-up event
 -Approximately 40 minutes per team from start to finish

	0700	0730	0800	0830	0900	0930	1000	1030	1100	1130	1200	1230	1300	1330	1400	1430	1500	1530	1600	1630	1700	1730	1800	1830	1900
16 APR																									
17 APR																									

Max 550 Individuals (1300-1430)
 Max 90 teams (1200-1330)

10 Teams Per Hour



Battle Fit Challenge (8th BDE)



Be All You Can Be

Task: The task is to assess the physical readiness of individuals as they complete three physically demanding events for time, push-ups, modified sit-ups, and a 1 mile run. This is an individual event which will produce a unique score for each Cadet based on their performance. For teams registered in the Masters Division, individual scores will be compiled into one collective team score which will contribute to overall team placement.

Conditions:

1. The Battle Fit Challenge will be conducted with 10 lanes. One grader and one timekeeper per lane.
2. The Battle Focused Challenge (BFC) is an individual assessment of Cadet physical fitness, but teams will remain together as individuals are assessed at each station.
3. Push-ups and modified sit-ups will be conducted on a covered athletic field.
4. The run route is a half a mile in length and will be run twice to record a 1 mile run time.
5. Judges will assess accurate repetitions at each station and log start and finish times for the run to capture accurate scores for each Cadet.
6. The uniform for this event consists of athletic shorts, t-shirt (team t-shirt), and athletic shoes. The athletic jacket may be worn if the weather conditions dictate, as decided by the team.

Standards:

1. Competitors will execute as a team and will remain in that team throughout the event.
2. First event will be individual 1 minute max push-up event. Upon completion, competitors will move to the sit-up bars. Upon completion, competitors will have 10 minute rest period before beginning the modified sit-up event.
3. Second event will be individual 1 minute max of modified sit-ups. Upon completion, competitors will have 10 minute rest period before beginning third and final event.
4. Third event will be 1-mile run. Teams will begin at the start point and run two laps around the .5 mile course.
5. The flow will be managed by the Event OIC. When all competitors have completed the 3x events, score sheets will be tallied by the event NCOIC.

Note: The specific rules and penalties for non-compliance may not be provided in the information. Referring to the official regulations or guidelines for detailed instructions and consequences regarding the Battle Fit Challenge event in the JROTC National Raider Challenge SOP is recommended



Battle Fit Challenge (8th BDE)



Be All You Can Be

- Tasks**
1. Push-ups
 2. Sit-up Bars
 3. Start/Finish Line

VA 1 - Observes Push-ups, Sit-ups and Start Finish Line

Team Holding Area

Spectators and Coaches will only be permitted on the spectator movement path and the approved viewing areas. Failure to comply with this request will result in a penalty for their competing team.

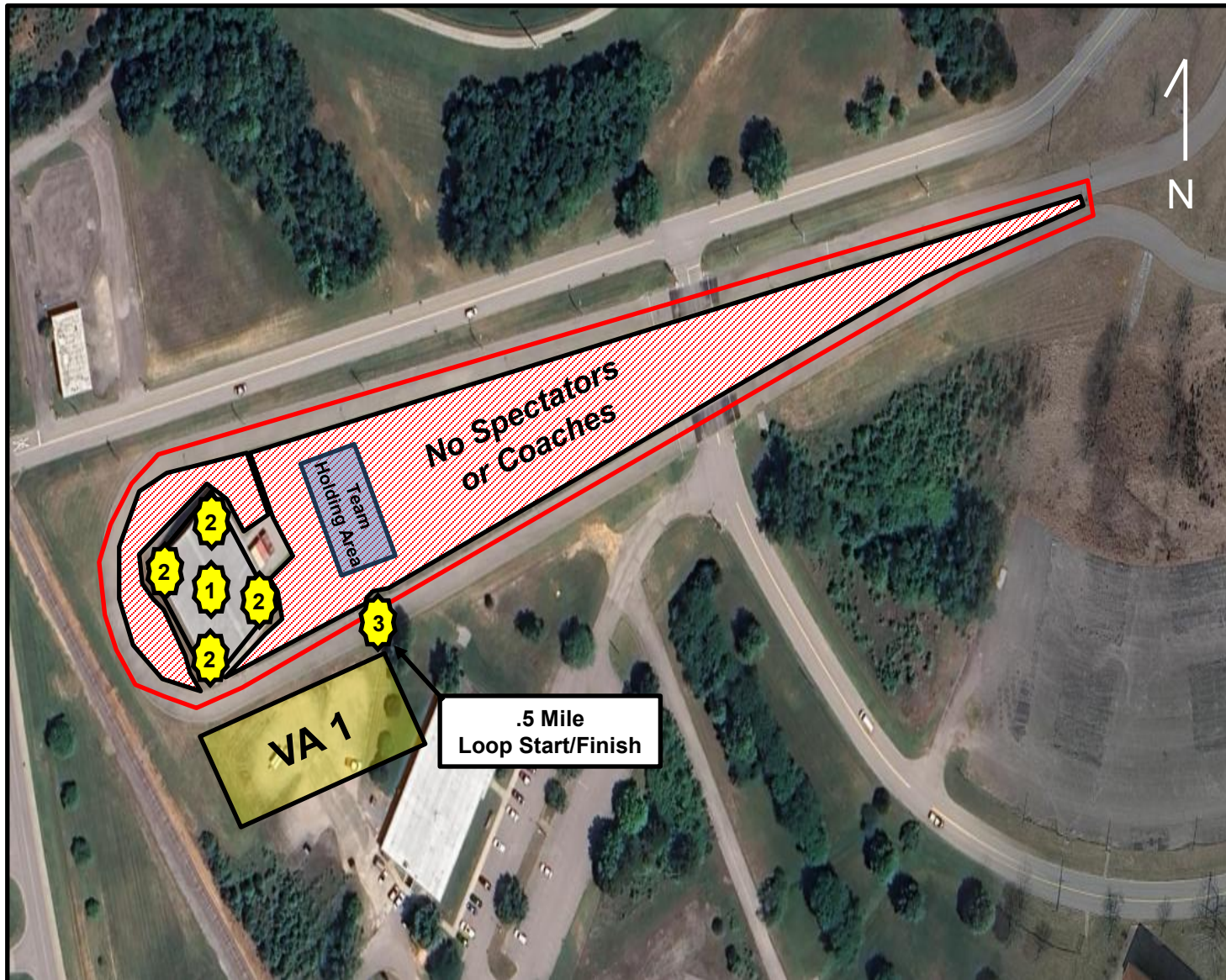



Physical Team Test (3rd BDE)



Be All You Can Be

Who : 3rd Brigade SROTC
What: Physical Team Test
Where: Fort Knox, KY
When: 17-18 APR 2026
OIC: TBD

- Key Tasks:**
1. Start/Finish
 2. Tunnel Crawl
 3. Water/Ammo Can Carry
 4. 40" Vault
 5. Agility Maze
 6. Agility Tire
 7. Atlas Stone
 8. 250lbs. Drag
 9. Tire Flip

Concept:
 The Physical Team Test will be executed in two lanes.
 Two graders located at each obstacle and timekeepers at start/finish per lane.

- Event Sequence:**
1. Team members must go through the tunnel crawl.
 2. The Water Cans (6) and Ammo Cans (4) will then be picked up from their designated area and returned placing them upright.
 3. All team members will go over the 40" vault.
 4. All team members then run in a column through the narrow Agility Maze.
 5. All team members run forward to the staggered tires where every team member attempts to place a single foot in each tire hole and continues running forward, moving directly into lifting atlas stones.
 6. A 250lb. weighted drag is then moved from behind a line on the ground around a circle and placed back at the original starting line.
 7. The team then proceeds to where there will be a large tire to flip within a 10-yard box.
 8. The team will sprint together to the finish line.

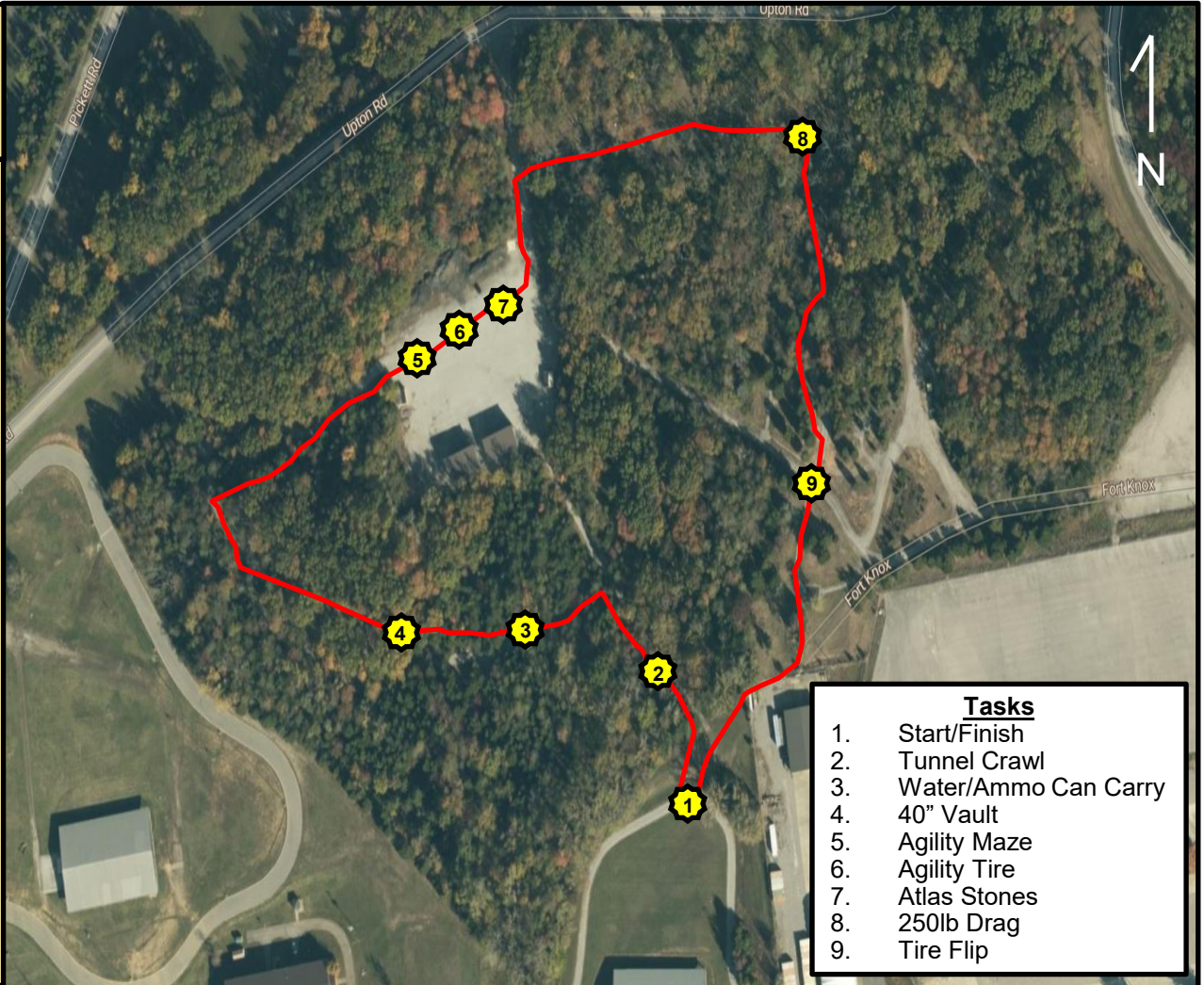

- Tasks**
1. Start/Finish
 2. Tunnel Crawl
 3. Water/Ammo Can Carry
 4. 40" Vault
 5. Agility Maze
 6. Agility Tire
 7. Atlas Stones
 8. 250lb Drag
 9. Tire Flip

	0700	0730	0800	0830	0900	0930	1000	1030	1100	1130	1200	1230	1300	1330	1400	1430	1500	1530	1600	1630	1700	1730	1800	1830	1900	
17 APR																										
18 APR																										



Physical Team Test (3rd BDE)



Be All You Can Be

Task: The task is to complete a half-mile course consisting of various physical obstacles as a team, demonstrating strength, stamina, strategy, and endurance. The team score is determined by the time it takes to complete the tasks, put all course items back in their starting positions, and finish the course.

Conditions:

1. The course will be approximately half a mile in length.
2. Teams will consist of 10 Cadets, in which they must start and finish with the entire team. Teams with less than 9 members will not be allowed to compete.
3. Judges will be stationed along the route to ensure compliance with the rules.
4. Multiple teams are allowed on the course at a given time, with a minimum of 5 minutes between staggered starts. Teams may pass slower teams during the route. But not to interfere with the other team's progression on the course.

Standards:

1. **Team Formation and Start:** a. The team will assemble behind a starting line. b. The grader will command, "Get Set, GO!" to initiate the start of the event. c. The clock starts upon the "GO" command.
2. **Course Details:** The course will include the following items (order of sequence may vary): a. 10' long, 30" diameter tunnel crawl. b. 30-yard Water Can carry (6 cans) and 60lb. Ammo Can carry (4 cans). c. 40" Team Vault. d. Speed Agility Maze (a tight zig-zag maze accomplished in column formation). e. Agility tires placed on the ground in a staggered pattern. f. Atlas Stone lift. g. 250lb. weighted, SKEDCO . h. Tire Flip.
3. **Event Completion:** a. The PTT is a .5-mile loop. On each task, Cadets must carry all items down and back to their original positions (sled, water cans, ammo cans and atlas stones) to reset the task for the next team. b. They can continue once all items are in their start positions.
4. **Item Handling:** a. Unless otherwise specified, Cadets can carry items in any manner as long as they do not abuse or throw them. b. Cadets must place water and ammo cans upright to avoid penalties.

Note: The specific rules and penalties for non-compliance may not be provided in the information. Referring to the official regulations or guidelines for detailed instructions and consequences regarding the Physical Team Test event in the JROTC National Raider Challenge SOP is recommended.



Physical Team Test (3rd BDE)

Be All You Can Be

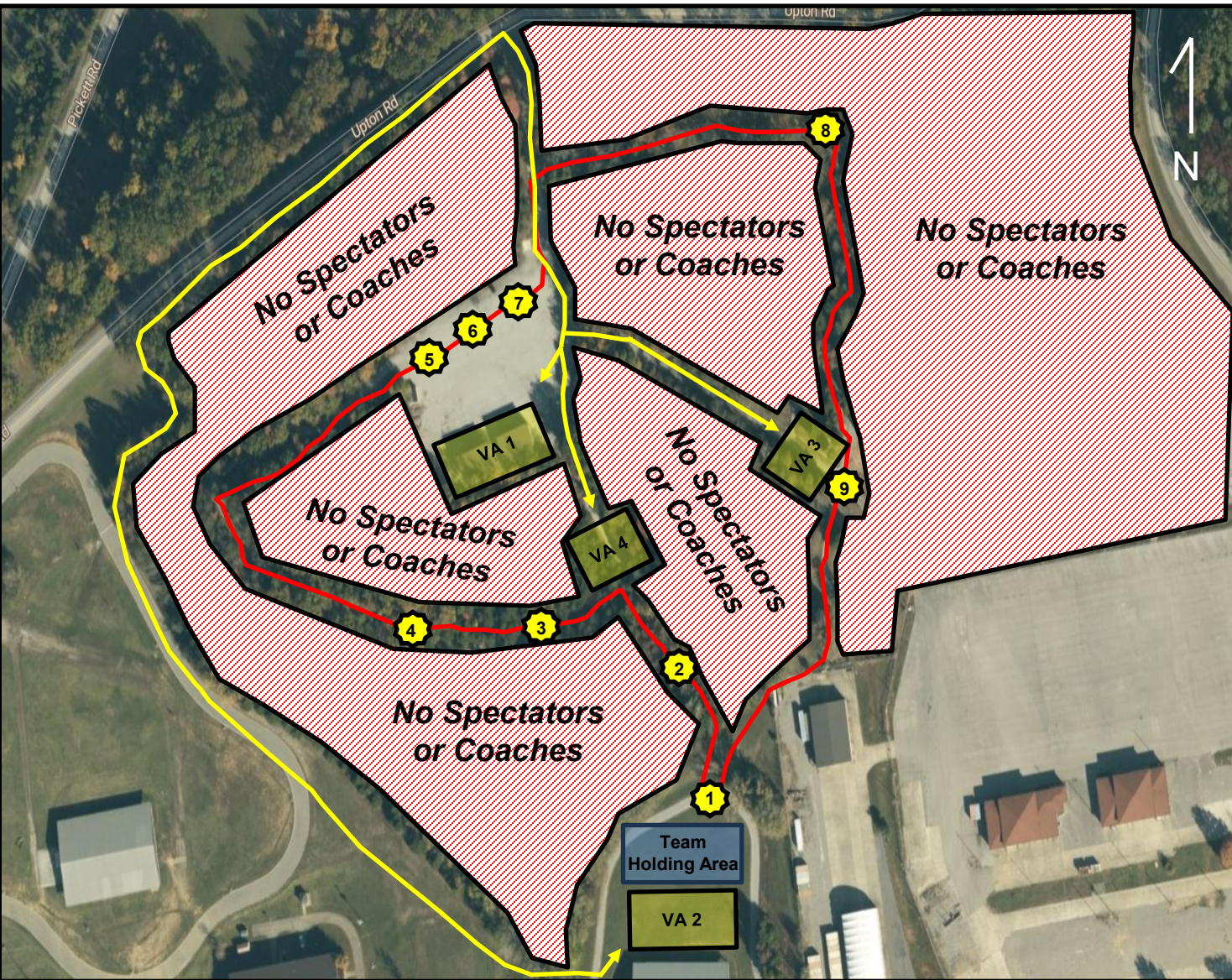

- Tasks**
1. Start/Finish
 2. Tunnel Crawl
 3. Water/Ammo Can Carry
 4. 40" Vault
 5. Agility Maze
 6. Agility Tire
 7. Atlas Stones
 8. 250lb Drag
 9. Tire Flip

VA 1

- Bleachers Area
- Observes Agility Maze, Agility Tire, and Atlas Stone
- Access to VA 3 and VA 4

VA 2

- Observes Team Holding Area and Start Finish Line.

VA 3

- Observes Tire Flip

VA 4

- Observes Tunnel Crawl

- Spectator Movement Path

Team Holding Area

Spectators and Coaches will only be permitted on the spectator movement path and the approved viewing areas. Failure to comply with this request will result in a penalty for their competing team.



Cross Country Rescue (2nd BDE)

Be All You Can Be

Who : 2nd Brigade SROTC
What: Cross Country Rescue
Where: Fort Knox, KY
When: 17-18 APR 2026
OIC: TBD

Key Tasks:

1. 8' Wall
2. Mud Pit
3. Over/Over
4. Tire Swing

Concept:

The Cross-Country Rescue will be executed in two lanes. Two graders located at each obstacle and timekeepers at start/finish per lane.

Event Sequence:

1. Teams run with 6 x 35lbs rucks to go over an 8' wall with all team members.
2. After completing the wall, teams will pick-up a simulated casualty after wall obstacle. Male teams (130lbs.) and Mixed and Female teams (100lbs.).
3. Team runs to a 40' long water/mud pit. The team will negotiate the pit with litter and rucksacks.
4. Team executes over/under obstacle (4' wide/40" high and 24" high). The team will go over the gates with their litter and rucks.
5. 6 of the 10 members will have 5 minutes to negotiate the obstacle. The other 4 members will hold/wear the 6 rucks and litter at the end of the obstacle until their team is complete or their 5 minutes is up, whichever comes first. The rucks and litter will never touch the ground..
6. At competition of the obstacle the team will secure their litters and move to the finish line.
7. Once the last person crosses the finish line with all gear having crossed the line, the time will stop and be recorded.
8. The team will then move into a testing tent to complete a 10-question, multiple choice medical skills test as a team. All wrong answers will serve as a time penalty.



<u>Tasks</u>	
1.	Start Line
2.	8' Wall
3.	Mud Pit
4.	Over/Under
5.	Tire Swing
6.	Finish Line

	0700	0730	0800	0830	0900	0930	1000	1030	1100	1130	1200	1230	1300	1330	1400	1430	1500	1530	1600	1630	1700	1730	1800	1830	1900	
17 APR																										
18 APR																										



Cross Country Rescue (2nd BDE)



Be All You Can Be

Task: The task is to complete a one mile "rescue" course through wooded terrain with obstacles while carrying rucksacks and a simulated casualty. The team must navigate the course, overcome obstacles, and reach the finish line to score a time.

Conditions:

1. The course is a one-mile route through wooded terrain with obstacles integrated along the route.
2. Teams will consist of 10 Cadets, in which they must start and finish with the entire team. Teams with less than 9 members will not be allowed to compete.
3. Judges will be stationed along the route to ensure compliance with the rules.
4. Multiple teams are allowed on the course at a given time, with a minimum of 5 minutes between staggered starts. Teams may pass slower teams during the route. But not to interfere with the other team's progression on the course.

Standards:

1. On the command "GET SET, GO," the team will immediately go over an 8' wall with all team members and the rucks. Failure to attempt this segment is a disqualification if not attempted, but teams may choose to bypass the wall after two failed attempts by taking a penalty.
2. After completing the wall, the team will pick up the simulated casualty litter and proceed to a 40' long water/mud pit. The team will run through the mud pit while carrying the litter and rucksacks.
3. Once the team completes the mud pit, they will continue with the litter and rucksacks along the marked trail.
4. The team will encounter a series of over and under obstacles, 4' wide with over obstacles at 40" high and more over obstacles at 24" high. The team will negotiate the obstacle with the litter and rucksacks. Once complete with the obstacle, teams will continue the marked trail.
5. The team will encounter a tire swing obstacle. The obstacle will have six tires suspended 3' off the ground. **6 of the 10 members will have 5 minutes to negotiate the obstacle. The other 4 members will hold/wear the 6 rucks and litter at the end of the obstacle until their team is complete or their 5 minutes is up, whichever comes first. The rucks and litter will never touch the ground.** The 6 members must negotiate the obstacle without making contact with the ground. If they touch the ground, they must go to the back of their team's line on the obstacle and then attempt to negotiate the obstacle again. At the competition of the 5 minutes, every member that hasn't successfully negotiated the obstacle will receive a minor penalty.
6. Finally, the team will move to the finish line with the rucksacks and litter. The time will stop once the last person crosses the finish line.

Note: The specific rules and penalties for non-compliance may not be provided in the information. Referring to the official regulations or guidelines for detailed instructions and consequences regarding the Cross Country Rescue event in the JROTC National Raider Challenge SOP is recommended.



Cross Country Rescue (2nd BDE)

Be All You Can Be

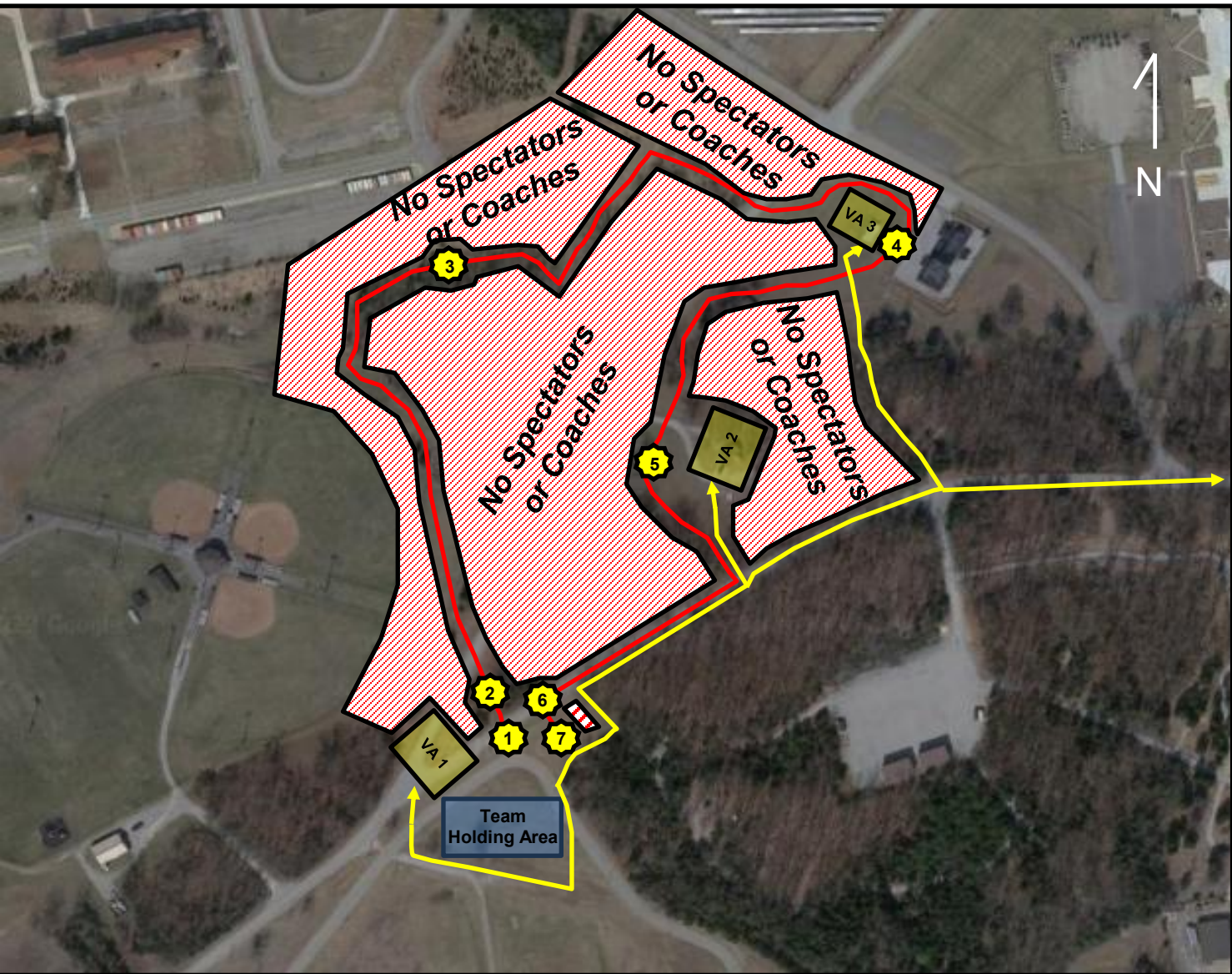

- Tasks**
1. Start Line
 2. 8' Wall
 3. Mud Pit
 4. Over/Under
 5. Tire Swing
 6. Finish Line
 7. Medical Test

- VA 1** - Observes Team Holding Area, Start and Finish Line, and 8' Wall.
- VA 2** - Bleacher Area; Observes Tire Swing Obstacle
- VA 3** - Bleacher Area; Observes Over/Under Obstacles
- Spectator Movement Path

Team Holding Area

Spectators and Coaches will only be permitted on the spectator movement path and the approved viewing areas. Failure to comply with this request will result in a penalty for their competing team.



1 Rope Bridge (4th BDE)

Be All You Can Be

Who : 4th Brigade SROTC
What: 1 Rope Bridge
Where: Fort Knox, KY
When: 17-18 APR 2026
OIC: TBD

Key Tasks:

- Swiss Seat Inspection
- Rope Bridge Build

Concept:
 The Rope Bridge will be executed in four lanes. Graders located on near and far side the site. Timekeepers at near side of each lane. Each team will have a max of 8 min.

Event Sequence:

- All teams will be required to execute with swiss seat.
- Teams will be inspected for correctness of their swiss seat.
- Teams will be given time to ready their rope bridge before starting.
- All team members will run forward roughly 20 yards from the starting line to the near side anchor point and begin building their 1-rope bridge.
- The team will then cross the river as outlined in the Raider Challenge SOP.
- Time runs until the entire team and all equipment are out of the water, across the river and on the far bank (to include the rope, bag (if used) carabineers), all knots and all snap-links are out of the rope.

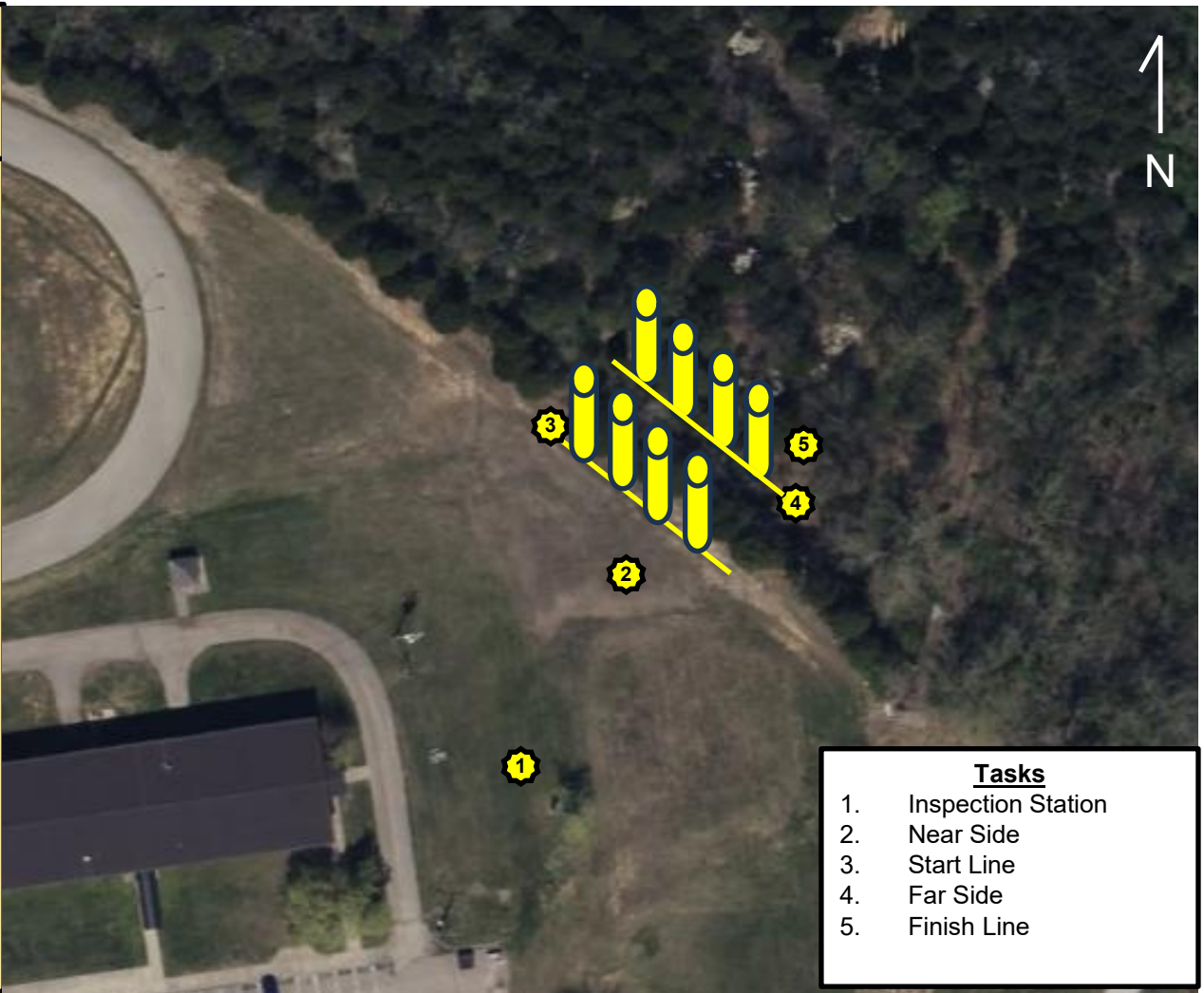

- Tasks**
- Inspection Station
 - Near Side
 - Start Line
 - Far Side
 - Finish Line

	0700	0730	0800	0830	0900	0930	1000	1030	1100	1130	1200	1230	1300	1330	1400	1430	1500	1530	1600	1630	1700	1730	1800	1830	1900
17 APR																									
18 APR																									



1 Rope Bridge (4th BDE)



Be All You Can Be

Task: The task is to construct a rope bridge following the Raider Challenge 1RB SOP, ensuring safety and utilizing proper techniques. The team must start and complete the bridge construction and cross it within 8 minutes to successfully complete this task.

Conditions:

1. The event will take place at rope bridge site over water and all teams will use the same crossing sites with multiple lanes available.
2. Teams will consist of 10 Cadets, in which they must start and finish with the entire team. Teams with less than 9 members will not be allowed to compete.
3. Teams are responsible for bringing their own rope bridge equipment, including a minimum 150 feet of rope. USACC will provide safety helmets, but teams can use their own helmets if desired.

Standards:

1. Bridge Construction and Execution:

- a. Swiss seats and waist seats must be tied prior to reporting to the rope bridge site. Swiss seats and ropes will be checked for safety compliance and are a graded event.
- b. No loops, bights, tape, or pre-tied knots are allowed on the rope.
- c. Upon arrival at the Start Point, two team members will be given a maximum of two minutes to prepare their rope next to the near side anchor. An 18-inch tail on either side of the rope may be placed apart from the rest of the rope to identify the top and bottom ends. The clock starts upon the command "GO." Cadets will run to the near side anchor point and build their rope bridge.
- d. Transport tightening system will utilize a wireman's knot or a figure eight slip knot.
- e. Aluminum carabiners are not authorized in transport tightening systems on the Rope Bridge (only steel). These links are allowed for the swiss seat used for individual Cadets. There is no limit on the number of snap links used in the transport knot.
- f. Time continues until the entire team and all equipment are out of the water, across the river, on the far bank, and all knots and snap-links are out of the rope. Team members are not permitted to touch the water unless they are the first/last Cadet across the obstacle, or they are suspended from the rope.
- g. The team must announce "TIME!" in a loud voice to indicate completion.
- h. The team with the fastest time, considering penalty points, will be the winner.
- i. Anchor Points:
 - i. Near Side Anchor Point: Anchor Point Knot must be a round turn and two half-hitches.
 - ii. Far Side Anchor Point: Round Turn with two half-hitches or a tensionless anchor (minimum of four wraps on the anchor).
 - iii. A minimum of one steel, locking carabiner or two steel, non-locking carabiners will be used at all anchor points. If the team is using steel, non-locking carabiner, the gates must be positioned opposite each other.

Note: The specific rules and penalties for non-compliance may not be provided in the information. Referring to the official regulations or guidelines for detailed instructions and consequences regarding the Rope Bridge event in the JROTC National Raider Challenge SOP and 1-Rope Bridge SOP is recommended.



1 Rope Bridge (4th BDE)

Be All You Can Be

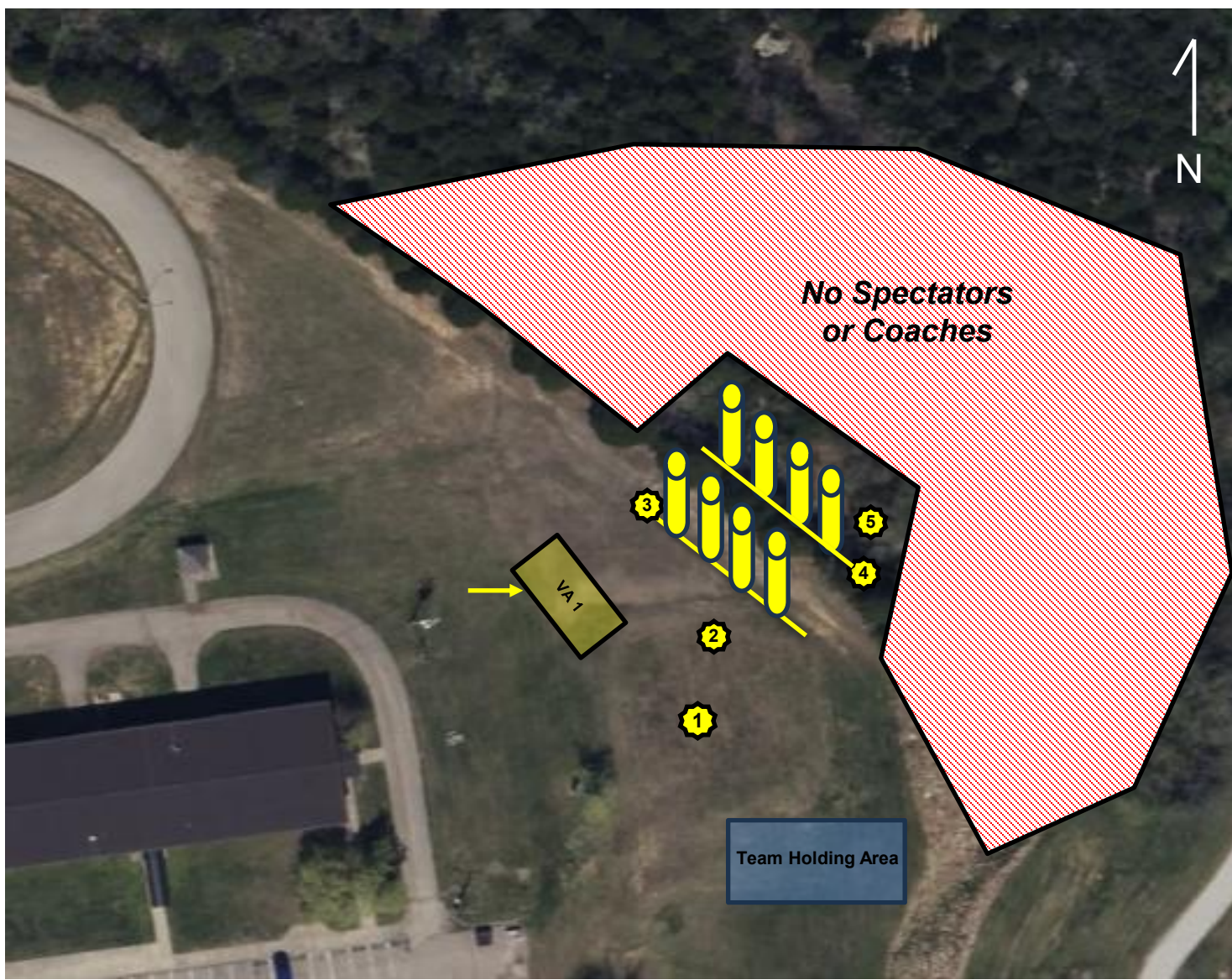

- Tasks**
1. Inspection Station
 2. Near Side
 3. Start Line
 4. Far Side
 5. Finish Line

VA 1 - Bleacher Area
 - Observes Near/Far Side Construction of Rope Bridge.

- Gravel Lot

- Spectator Movement Path

Team Holding Area

Spectators and Coaches will only be permitted on the spectator movement path and the approved viewing areas. Failure to comply with this request will result in a penalty for their competing team.

*Only 1 Coach will be allowed across the Bridge to sign the score card. NO COACHING.



Raider Gauntlet (5th BDE)

Be All You Can Be

Who : 5th Brigade SROTC
What: Raider Gauntlet
Where: Fort Knox, KY
When: 17-18 APR 2026
OIC/NCOIC: TBD

- Key Tasks:**
- 12' Wall
 - Over/Over Vault
 - Culvert Pipe
 - L-Shaped Culvert
 - Suspended Tire
 - Horizontal Ladder
 - Window Obstacle
 - Inverted Wall
 - Low Crawl
 - 8' Wall

Concept:
 The Raider Gauntlet will be executed in two lanes. Two graders located at each obstacle and timekeepers at start/finish per lane.

- Event Sequence:**
- 1-mile course that is executed over rolling terrain with 10 obstacles along the route.
 - Teamwork is necessary to safely complete all obstacles on the course.
 - Upon completion of the final obstacle, the team will cross the finish line with time stopping when the last Cadet crosses.
 - Latter starting teams may pass the earlier starting teams on the course should they catch up to them.

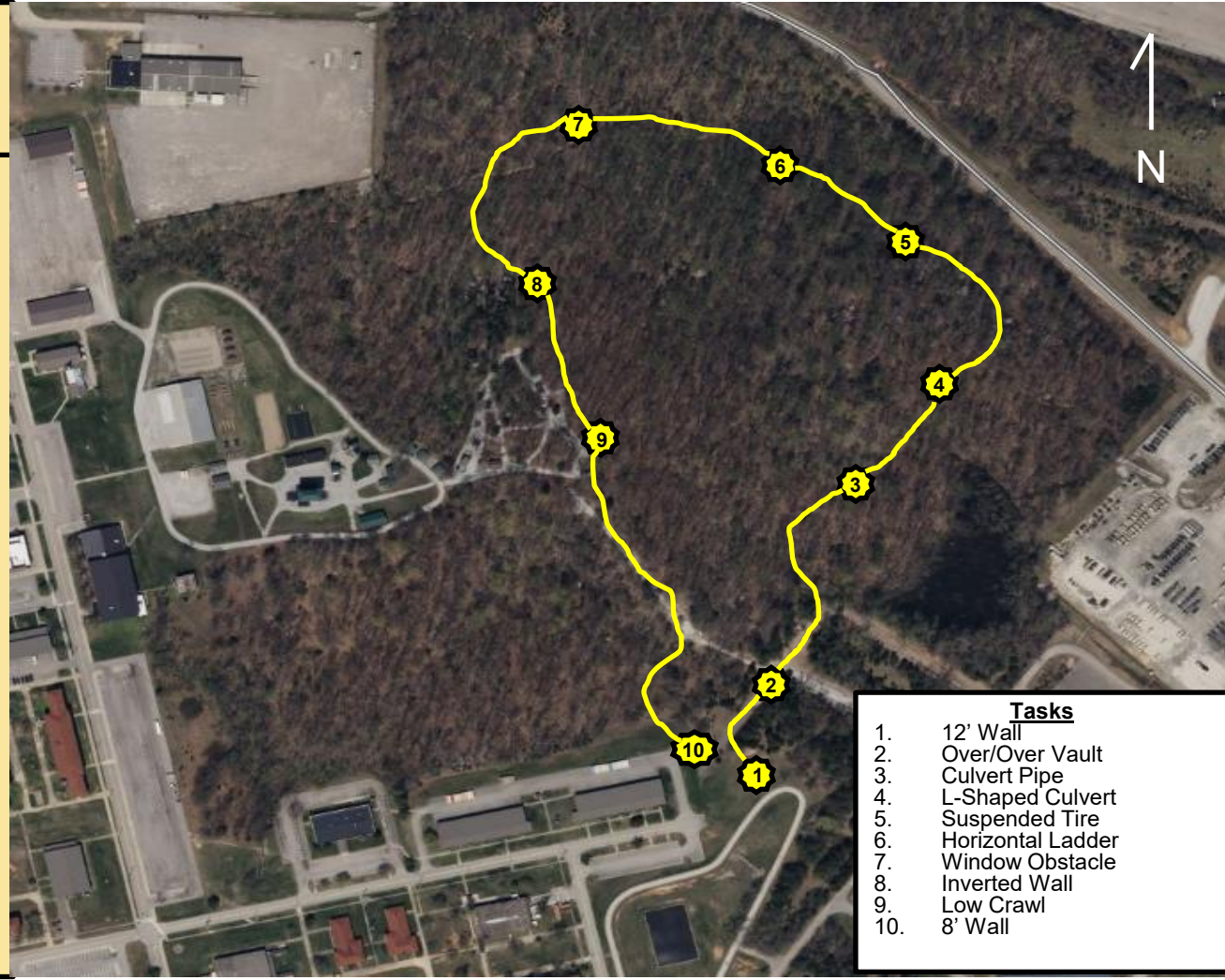

- Tasks**
- 12' Wall
 - Over/Over Vault
 - Culvert Pipe
 - L-Shaped Culvert
 - Suspended Tire
 - Horizontal Ladder
 - Window Obstacle
 - Inverted Wall
 - Low Crawl
 - 8' Wall

	0700	0730	0800	0830	0900	0930	1000	1030	1100	1130	1200	1230	1300	1330	1400	1430	1500	1530	1600	1630	1700	1730	1800	1830	1900	
17 APR																										
18 APR																										



Raider Gauntlet (5th BDE)



Be All You Can Be

Task: The task is to complete a 1-mile event through rolling terrain with various obstacles. The team must navigate the course, overcome obstacles, and reach the finish line to score a time.

Conditions:

1. The event takes place in rolling terrain with numerous obstacles throughout the course. No equipment is required for this course.
2. Teams will consist of 10 Cadets, in which they must start and finish with the entire team. Teams with less than 9 members will not be allowed to compete.
3. Judges will be stationed along the route to ensure compliance with the rules.
4. Multiple teams are allowed on the course at a given time, with a minimum of 5 minutes between staggered starts. Teams may pass slower teams during the route. But not to interfere with the other team's progression on the course.

Standards:

1. The course will consist of multiple obstacles over a 1-mile course.
2. On the command "GET SET, GO," time will start, and teams will begin.
3. Obstacles include:
 - a. 12' high wall: All teams must go over this wall. All teams must complete or execute 2 attempts to go over this wall. After clearing the wall, the team will continue along the course.
 - b. Series of over and over vaults: Cadets must go over 4-foot wide 40" high obstacles and over 4-foot wide 24" obstacles.
 - c. 2x 30' long, 30" diameter culverts per lane, one suspended and free swinging: All Cadets must go through these culverts.
 - d. 30' long, 30" diameter L-shaped culverts: All Cadets must go through these culverts.
 - e. Suspended 23" diameter radial tire obstacle: All Cadets must go through this obstacle.
 - f. 25' Horizontal Lader.
 - g. 3.5' square window obstacle: All Cadets must go through this obstacle.
 - h. 7' ramp wall with ropes: Cadets must go or execute 2 attempts to go over this wall.
 - i. Low Crawl 30'
 - j. 8' wall: All teams must go over this wall. All teams must complete or execute 2 attempts to go over this wall. After clearing the wall, the team will continue along the course.
4. Time will end when the last Cadet in the team crosses the finish line.

Note: The specific rules and penalties for non-compliance may not be provided in the information. Referring to the official regulations or guidelines for detailed instructions and consequences regarding the Raider Gauntlet event in the JROTC National Raider Challenge SOP is recommended.



Raider Gauntlet (5th BDE)

Be All You Can Be

Tasks

1. 12' Wall
2. Over/Over Vault
3. Culvert Pipe
4. L-Shaped Culvert
5. Suspended Tire
6. Horizontal Ladder
7. Window Obstacle
8. Inverted Wall
9. Low Crawl
10. 8' Wall

VA 1 - Bleacher Area
- Observes 12' Wall, Start and Finish Line, and Team Holding Area

VA 2 - Observes Over/Over Vault

- Spectator Bus drop-off

- Spectator Movement Path

Team Holding Area

Spectators and Coaches will only be permitted on the spectator movement path and the approved viewing areas. Failure to comply with this request will result in a penalty for their competing team.





5K Run (7th BDE)

Be All You Can Be

Who : 7th Brigade SROTC
What: 5K Run
Where: Fort Knox, KY
When: 17-18 APR 2026
OIC/NCOIC: TBD

Key Tasks:
 1. 5K Run (New Route)

Concept:
 The 5K run will be executed in one lane. Cadre located each Checkpoint and timekeepers at start/finish.

Event Sequence:

- 3.4 Mile team run on a route through rolling terrain in the TA 56 training area.
- Team run with no gear required to carry on the course.
- The route is on a marked path through woods that goes through varying terrain. At points, the path can be narrow, necessitating a single file movement formation.
- Teams will start together, run together and finish together while on the course.
- Each team must cross the finish line with all team members inside a 10-yard box at the finish.
- Teams may not carry or otherwise fully support a Cadet on the course however; teams can help a struggling or injured team member.
- Cadets will run the course in OCP and boots. Water points will also be staged throughout the course at designated checkpoints.



Key

SP/RP: Start/Finish Point

- Checkpoint 1
- Checkpoint 2
- Checkpoint 3
- Checkpoint 4
- Checkpoint 5
- Checkpoint 6
- Checkpoint 7
- Checkpoint 8
- Checkpoint 9
- Checkpoint 10

	0700	0730	0800	0830	0900	0930	1000	1030	1100	1130	1200	1230	1300	1330	1400	1430	1500	1530	1600	1630	1700	1730	1800	1830	1900	
17 APR																										
18 APR																										



5K Run (7th BDE)



Be All You Can Be

Task: The task is for a 10-member team to run together on a 5K route through rolling terrain. The objective is to maintain unity and safety as a team throughout the run, with all team members crossing the finish line within a designated 10-yard box.

Conditions:

1. The event takes place in rolling terrain with numerous obstacles throughout the course. No equipment is required for this course.
2. Teams will consist of 10 Cadets, in which they must start and finish with the entire team. Teams with less than 9 members will not be allowed to compete.
3. Judges will be stationed along the route to ensure compliance with the rules.
4. Multiple teams are allowed on the course at a given time, with a minimum of 2.5 minutes between staggered starts. Teams may pass slower teams during the route. But not to interfere with the other team's progression on the course.
5. The uniform for this event consists of ACU pants, t-shirt, and boots. The jacket may be worn if the weather conditions dictate, as decided by the team. Athletic shoes are not allowed.

Standards:

- a. All teams will start and finish the run together, ensuring team integrity is maintained throughout the course.
- b. Each team will ensure all members are within the designated 10-yard box throughout the course at all times.
- c. Teams that fail to finish with all members will receive a penalty.
- d. Running ahead provides no advantage to teams and will result in a penalty for failing to stay together as a team.

Note: The specific rules and penalties for non-compliance may not be provided in the information. Referring to the official regulations or guidelines for detailed instructions and consequences regarding the 5K Run event in the JROTC National Raider Challenge SOP is recommended.



5K Run (7th BDE)



Be All You Can Be

Key

SP/RP: Start/Finish Point
 1. Checkpoint 1
 2. Checkpoint 2
 3. Checkpoint 3
 4. Checkpoint 4
 5. Checkpoint 5
 6. Checkpoint 6
 7. Checkpoint 7
 8. Checkpoint 8
 9. Checkpoint 9
 10. Checkpoint 10

VA 1 - Bleacher Area
 - Observes Start Line, Finish Line and Team Holding Area

- Spectator Movement Path

- Spectator Bus drop-off

Team Holding Area

Spectators and Coaches will only be permitted on the spectator movement path and the approved viewing areas. Failure to comply with this request will result in a penalty for their competing team.

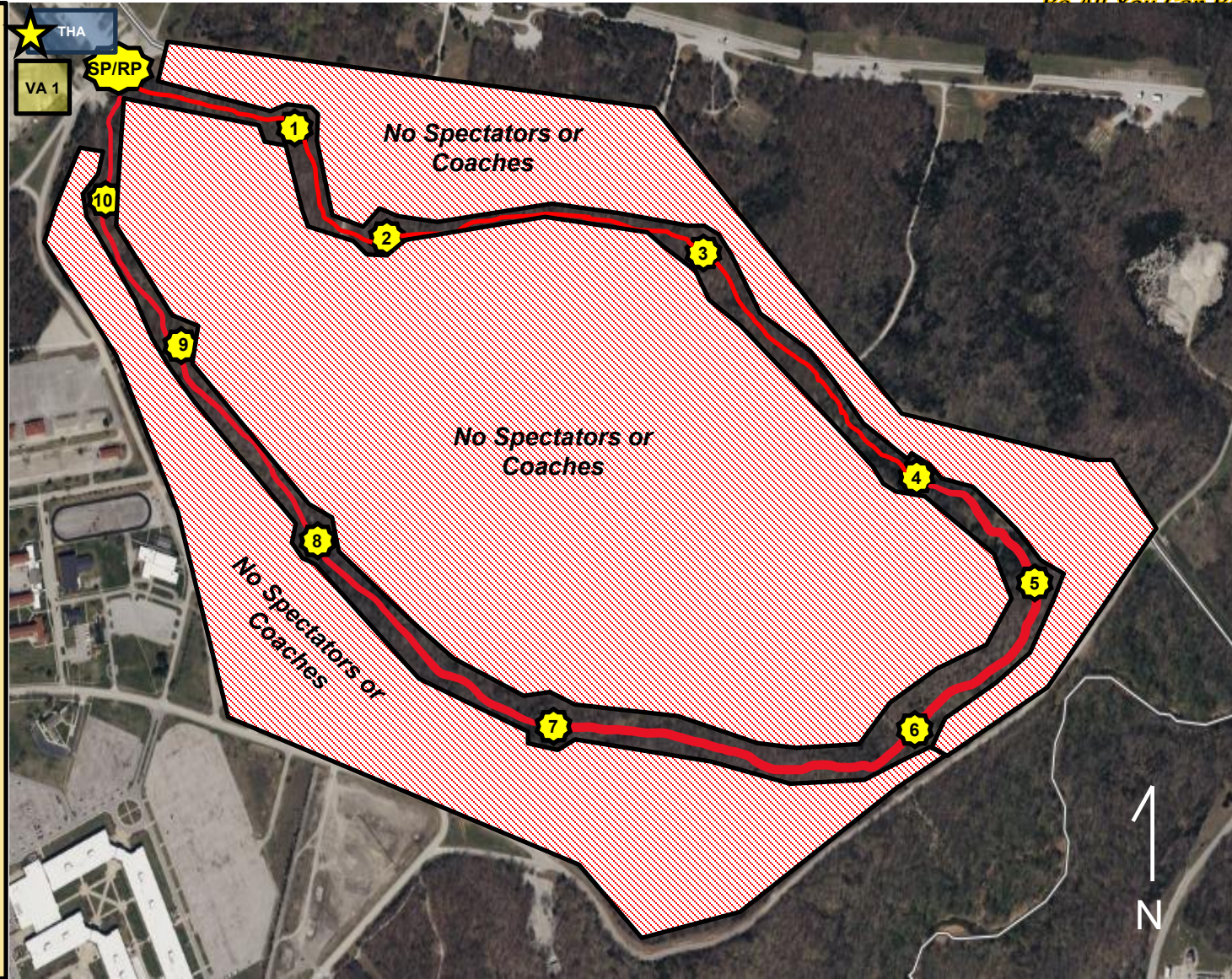



Leadership Excellence

Be All You Can Be

National Raider Challenge Competition

Ultimate Raider



Leaders for Life

Ultimate Raider



Be All You Can Be

Who : 6th Brigade SROTC

What: Ultimate Raider

Where: Fort Knox, KY

When:

OIC/NCOIC:

Key Tasks:

1. Continuous 4.2 mile run with equipment
2. 4 integrated events with critical thinking
3. Equipment inspections

Conditions:

The Ultimate Raider will be executed in 5 waves of 5 teams. Two graders located at each obstacle and timekeepers at start/finish. Event executed as a full team (24 Teams)

Standards:

1. Teams from the top 5 Masters and top 3 All-Service Male, Mixed, and Female Sub-Divisions will be selected to compete in the Ultimate Raider (24 total teams).
2. The Ultimate Raider results will be tabulated into the competing teams overall scoring totals. This event is no longer weighted higher than Saturday events.
3. Teams will be given their equipment and 30 min to create a load plan for the event.
4. Teams navigate a 4.2-mile cross country course with 102.2 lbs of equipment and 4 grueling events to which each team member must traverse.
5. Teams will use critical thinking skills to complete obstacles with the equipment provided. Teams must start and finish with all equipment.
6. At the completion of the course, the time will stop for the team, and they will move to a nearby staging area to complete a final equipment layout.
7. Penalties will be assessed for failure to complete an obstacle, not finishing with all members of your team, and not having all of your equipment after you cross the finish line.

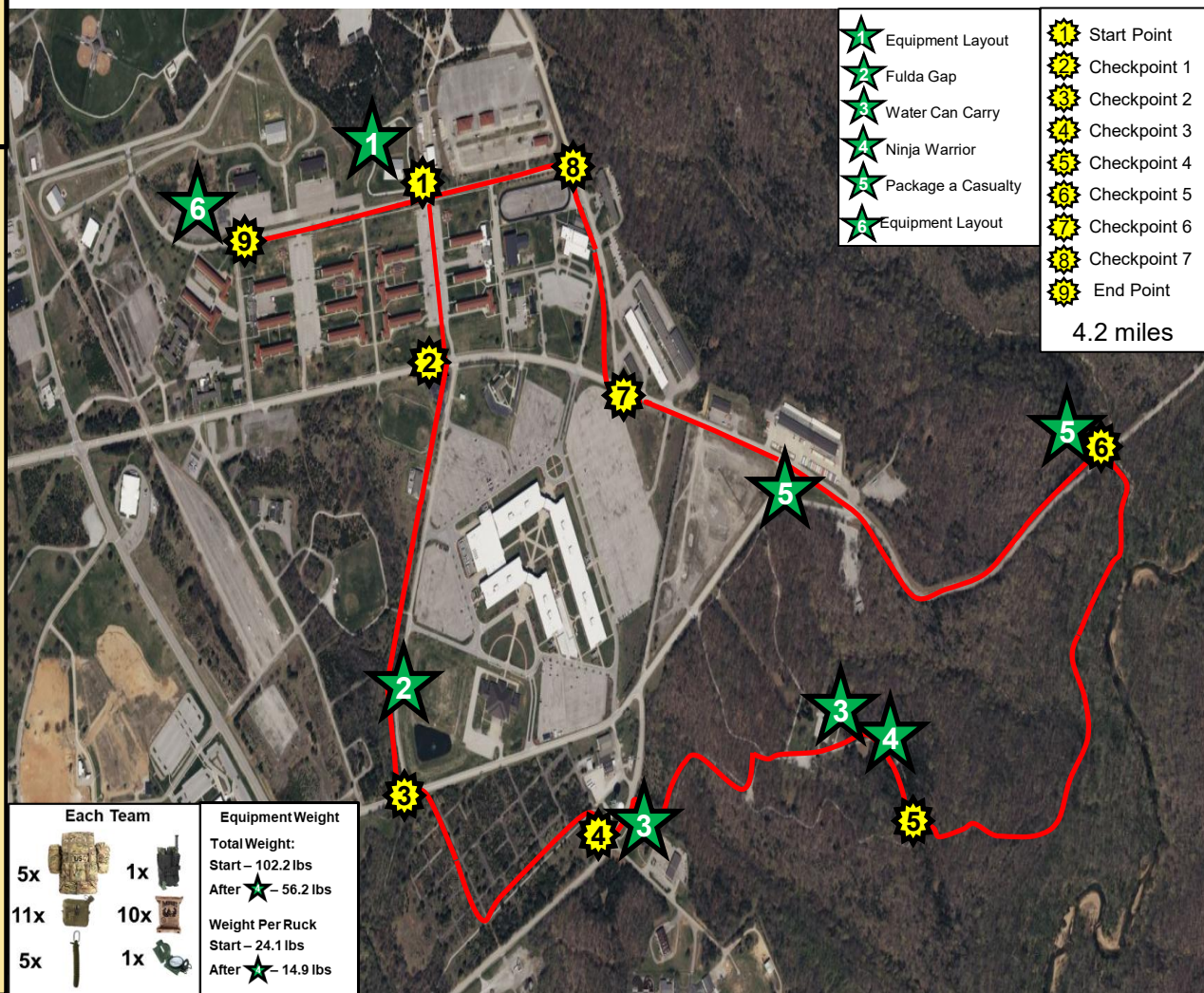

Each Team		Equipment Weight
5x	1x	Total Weight:
11x	10x	Start - 102.2 lbs
5x	1x	After - 56.2 lbs
		Weight Per Ruck
		Start - 24.1 lbs
		After - 14.9 lbs

	0700	0730	0800	0830	0900	0930	1000	1030	1100	1130	1200	1230	1300	1330	1400	1430	1500	1530	1600	1630	1700	1730	1800	1830	1900	
19 APR	Team Trans	Equip Layout	Wave #1		Wave #2		Wave #3		Wave #4		Wave #5															
										Award Ceremony								Teams Depart								

Updated: 3-Apr-26 11:43



Ultimate Raider (6th BDE)



Be All You Can Be

Task: Teams from the top 5 Masters and top 3 All-Service Male, Mixed, and Female Sub-Divisions will be selected to compete in the Ultimate Raider (24 total teams). The objective is for the team to stay together throughout the course, complete all the tasks successfully, and cross the finish line together.

Conditions:

1. The Ultimate Raider results will be tabulated into the competing teams overall scoring totals. This event is no longer weighted higher than Saturday events.
2. Cadets will wear OCPs with boots for this run, and teammates can select to wear OCP shirts as long as both are in the same uniform.
3. Teams navigate a 4-mile cross country course with 102.2 lbs of equipment and 4 grueling obstacles to which each team member must traverse.
4. Supervision: The event will be conducted in a controlled and supervised environment, ensuring the safety and fairness of the competition.
5. Time Intervals: The Ultimate Raider will be executed in 5 waves of 5 teams with 10 minutes between each wave. Time will end when the team has crossed the finish line together after completing all the tasks. Teams may pass slower teams during the route. But not to interfere with the faster team's progression on the course.

Standards:

1. Team Unity and Finish Line:
 - a. The team must stay together throughout the course. Teams that do not cross the finish line together will be disqualified from the event and not eligible for any overall Division trophies.
2. Course Details:
 - a. Teams will be given their equipment and 30 min to create a load plan for the event.
 - b. On the command of "GET SET, GO," Teams navigate a 4-mile cross country course with 102.2 lbs of equipment and 4 grueling obstacles to which each team member must traverse. Teams will use critical thinking skills to complete obstacles with the equipment provided. Teams must start and finish with all equipment. At the completion of the course, the time will stop for the team, and they will move to a nearby staging area to complete a final equipment layout. Penalties will be assessed for failure to complete an obstacle, not finishing with all members of your team, and not having all of your equipment after you cross the finish line.
3. Penalties and Disqualification:
 - a. Teams will receive penalties if they bypass or fail to complete any obstacles.
 - b. Teams that deviate off the course will be disqualified. Course will be marked with checkpoints along the route.

Note: The specific rules and penalties for non-compliance may not be provided in the information. Referring to the official regulations or guidelines for detailed instructions and consequences regarding the Ultimate Raider event in the JROTC National Raider Challenge SOP is recommended.



Ultimate Raider (6th BDE)



Be All You Can Be

- 1 Start Point
 - 2 Checkpoint 1
 - 3 Checkpoint 2
 - 4 Checkpoint 3
 - 5 Checkpoint 4
 - 6 Checkpoint 5
 - 7 Checkpoint 6
 - 8 Checkpoint 7
 - 9 End Point
- 4.1 miles

VA 1 Viewing Areas
 -Observes Start Point, Fulda Gap and Finish Line

-Competitor Route
 -Spectator Route (Gold Chain)

THA Team Holding Area
 -Start and Finish line for equipment inventory

Spectators and Coaches will only be permitted on the spectator movement path and the approved viewing areas. Failure to comply with this request will result in a penalty for their competing team.

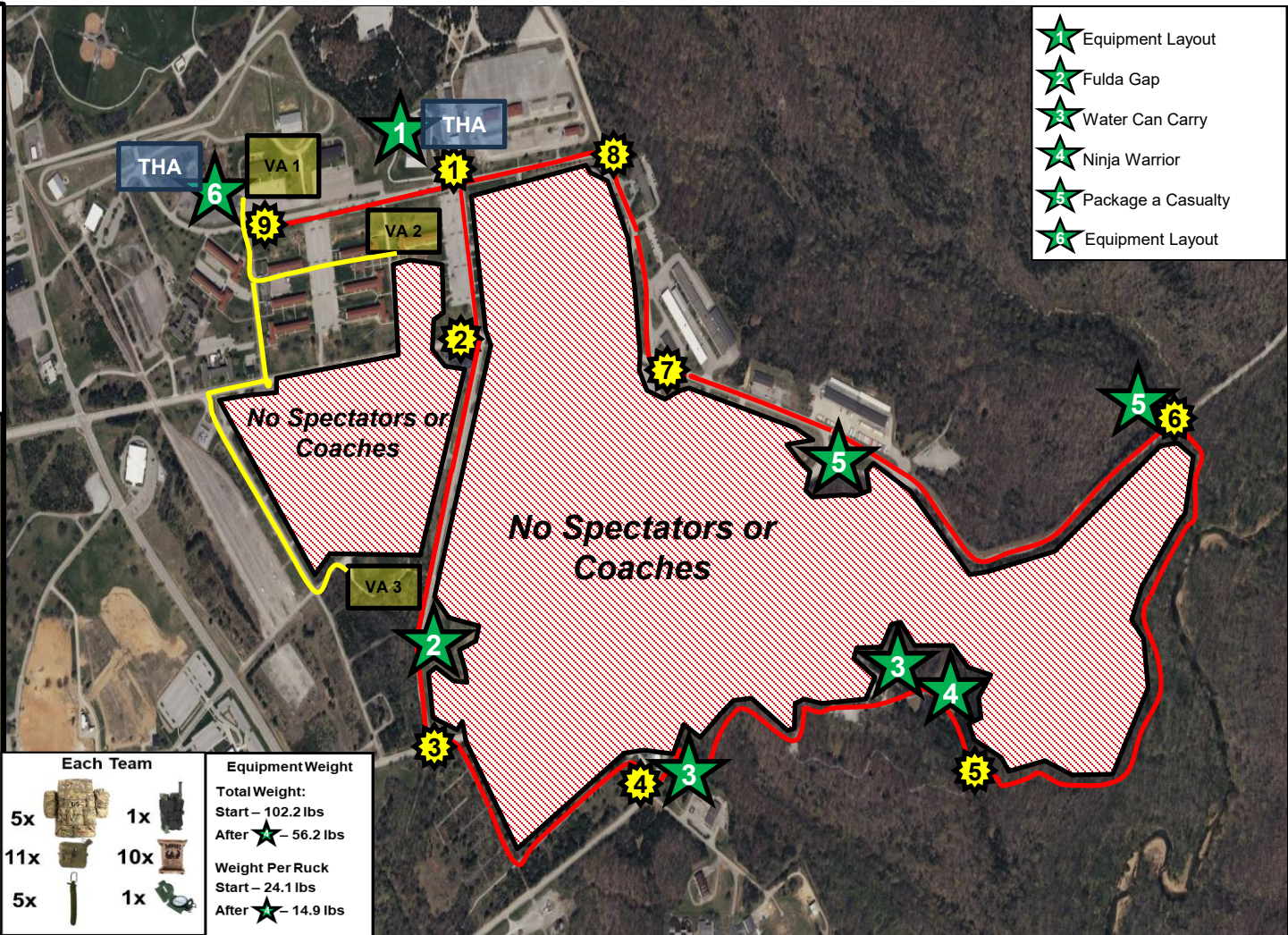

- 1 Equipment Layout
- 2 Fulda Gap
- 3 Water Can Carry
- 4 Ninja Warrior
- 5 Package a Casualty
- 6 Equipment Layout

Each Team		Equipment Weight	
5x	1x	Total Weight:	
11x	10x	Start -	102.2 lbs
5x	1x	After	56.2 lbs
		Weight Per Ruck	
		Start -	24.1 lbs
		After	14.9 lbs

	0700	0730	0800	0830	0900	0930	1000	1030	1100	1130	1200	1230	1300	1330	1400	1430	1500	1530	1600	1630	1700	1730	1800	1830	1900
19 APR	Team Trans	Equip Layout	Wave #1	Wave #2	Wave #3	Wave #4	Wave #5			Award Ceremony							Teams Depart								

Updated: 3-Apr-26 11:43

Fulda Gap (Near Caruso Sports Complex)

Be All You Can Be

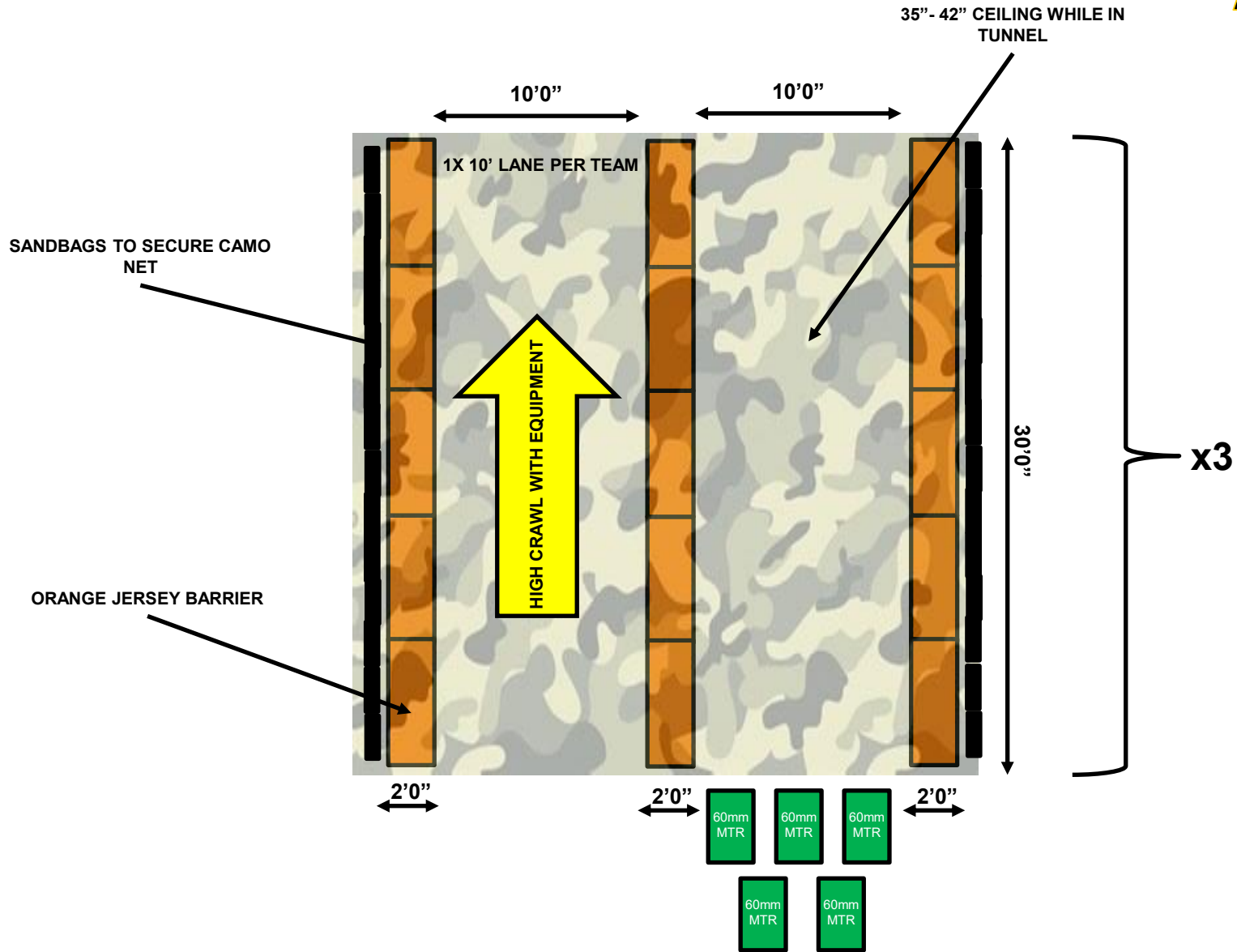

Ninja Warrior (Heard Park)

Be All You Can Be

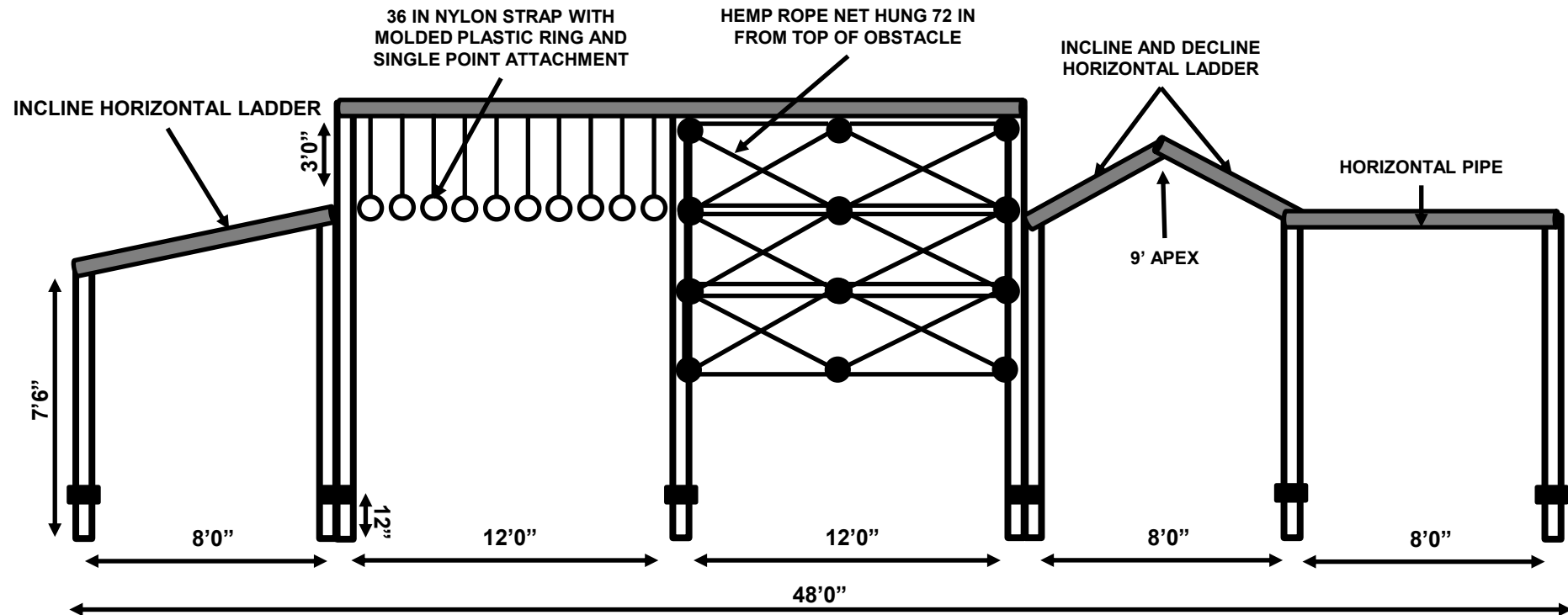



Leadership Excellence



Be All You Can Be

National Raider Challenge Competition

Event Scoring



Leaders for Life



Scoring



Be All You Can Be

Competing teams may receive several penalties on both obstacles or courses by a judge or event official. They are shown below:

Disqualified (DQ) - The team performed in a manner where the judge or event official removed the team from the competition scoring process for that event. The team would no longer be eligible for any overall awards or any awards in the event they are disqualified from. The penalty assessed will be 99:99 for that event.

Did Not Finish (DNF) - The team performed in a manner where a judge or event official directed the teams to end their competition on a specific course either due to time or injury. The penalty assessed will be 79:99 for that event.

Failure to Attempt (FTA) – The team was deemed by a judge or event official to have failed to properly attempt an obstacle. Attempt will be defined as, “to make a significant effort to accomplish the task given”. A Major Penalty assessed for an FTA.

Failure to Complete (FTC) - The team was deemed by a judge or event official to have Failed to Complete an obstacle. This is after two attempts, or a judge may direct them past an obstacle due to time, injury or improper technique which may cause injury. A Standard Penalty will be assessed for an FTC.

Minor Penalty (MINOR) - 30 second time addition to the team's overall event time per occurrence.

Standard Penalty (STANDARD) – 1 minute time addition to the team's overall event time per occurrence.

Major Penalty (MAJOR) - 10 minutes time addition to the team's overall event time per occurrence.



Scoring Concept



Be All You Can Be

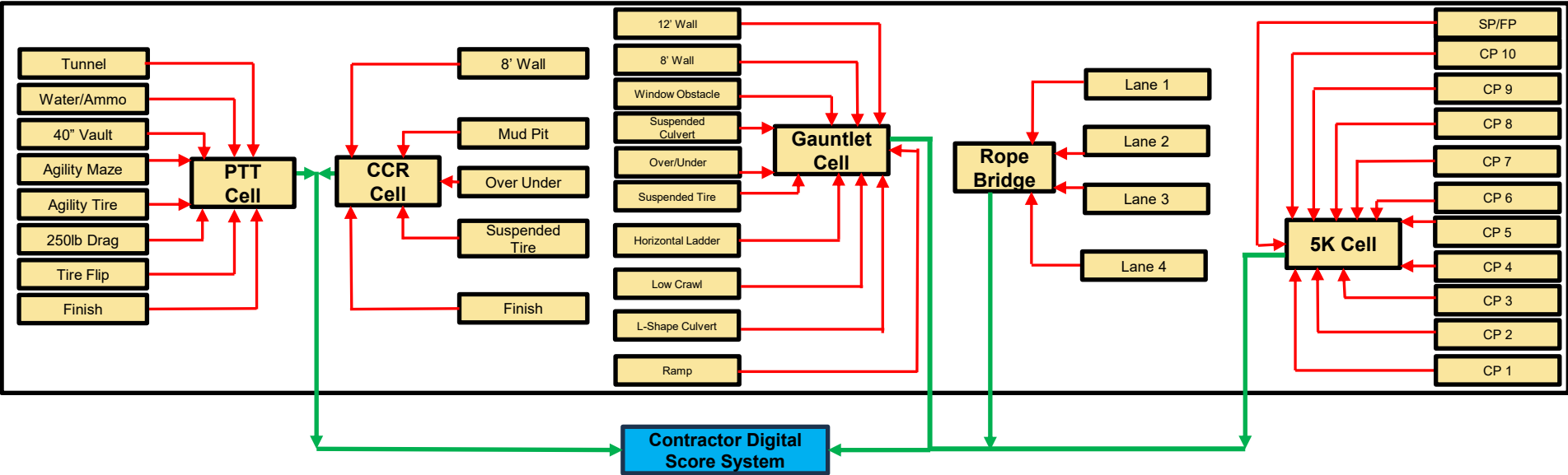

- Sequence of Events:**
1. Lane Cadre report penalty data to Event Cell
 2. Event Cell annotates data in digital system
 3. Updates are immediate and transferred to Scoring Desk
 4. Scoring Desk transfers to Validation and Publication Desk
 5. Master scoreboard will be published in the Raider TOC throughout the competition
 6. Scores are closed to teams and spectators

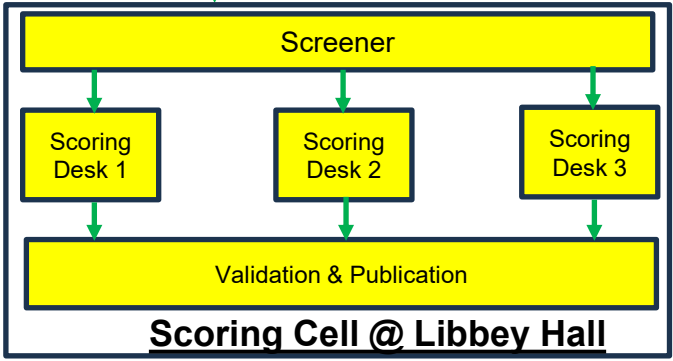

* Lane Cadre are only reporting penalties observed or emergencies on lane. All times will be recorded by Event Cell.



Leadership Excellence



Be All You Can Be

National Raider Challenge Competition

Event Protest Flowchart



Leaders for Life

Protests



Be All You Can Be

Coach Will Only Initiate Protest When Reviewing and Signing Scoresheet at the Competition of the Lane

Team Coach Determines a Protest is Necessary

Coach Protest with Event OIC
Coaches Will Not Initiate Protest at an Obstacle/Task/Lane Evaluator

Major Penalty Assessed to Team – Lane Protest No Longer Authorized

Time Protest

Penalty Protest

*All Unsportsmanlike Conduct Penalties are Not Subject to Protest

Coach has clear visible evidence

Coach articulates clear justification for protest

Yes

No

Yes

No

OIC Authorizes Time Adjustment to Scoresheet

OIC Disapproves Time Protest

OIC Authorizes Removal of Penalty Scoresheet

OIC Disapproves Penalty Protest

LEVEL 1 PROTEST

If a Coach Disagrees with the Event OIC Decision, They May Elevate their Protest to the Site OIC for a Final Decision.
***Protest are Not Authorized to the Competition OIC.**

LEVEL 2 PROTEST



Leadership Excellence

Be All You Can Be

National Raider Challenge Competition

Demonstrations, Static Displays and College Row



Leaders for Life

Demonstrations

Be All You Can Be

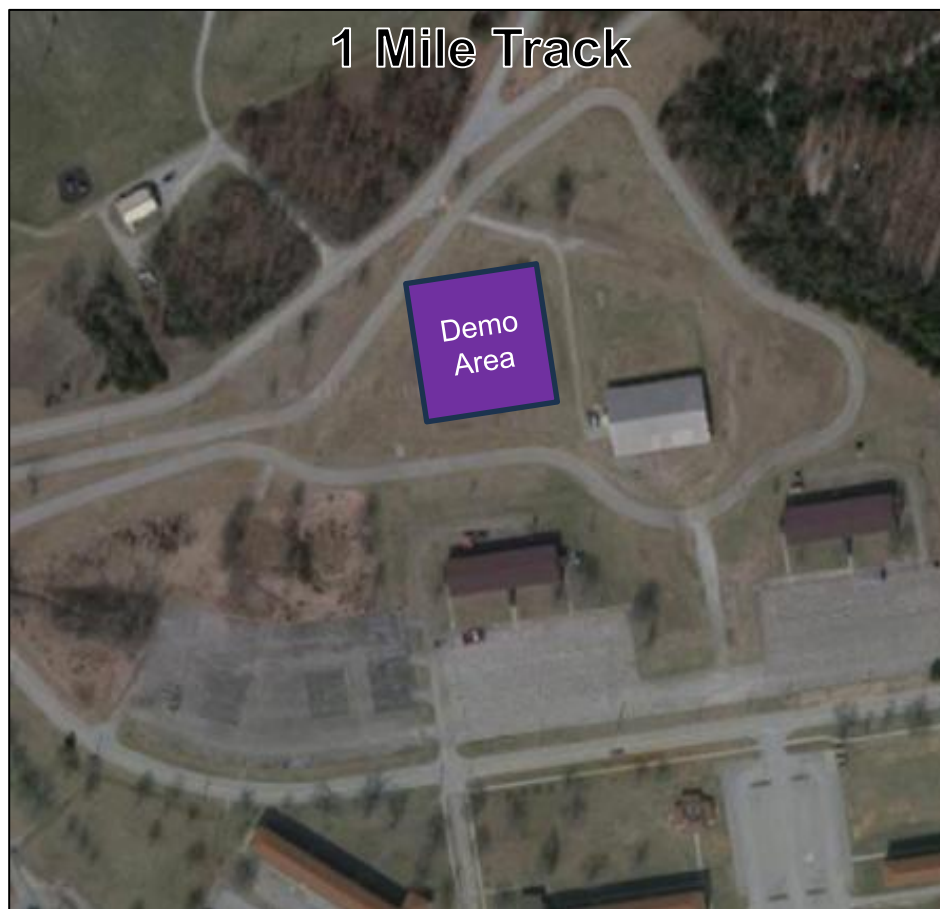

17 APRIL (FRIDAY)

- 1400: Fort Knox MWD Demonstrations

18 APRIL (SATURDAY)

- 1400: Fort Knox MWD Demonstrations
- 1155 – United States Military Academy – Black Knights Parachute Demo Team

19 APRIL (SUNDAY)

- 1100: USACC Air Assault / Knock Out a Bunker
- 1155: United States Military Academy – Black Knights Parachute Demo Team

Static Display Layout

Be All You Can Be

Display Timelines:
 16 APR: 12:00 pm – 6:00 pm
 17 APR: 8:00 am – 7:30 pm
 18 APR : 8:00 am – 6:00 pm

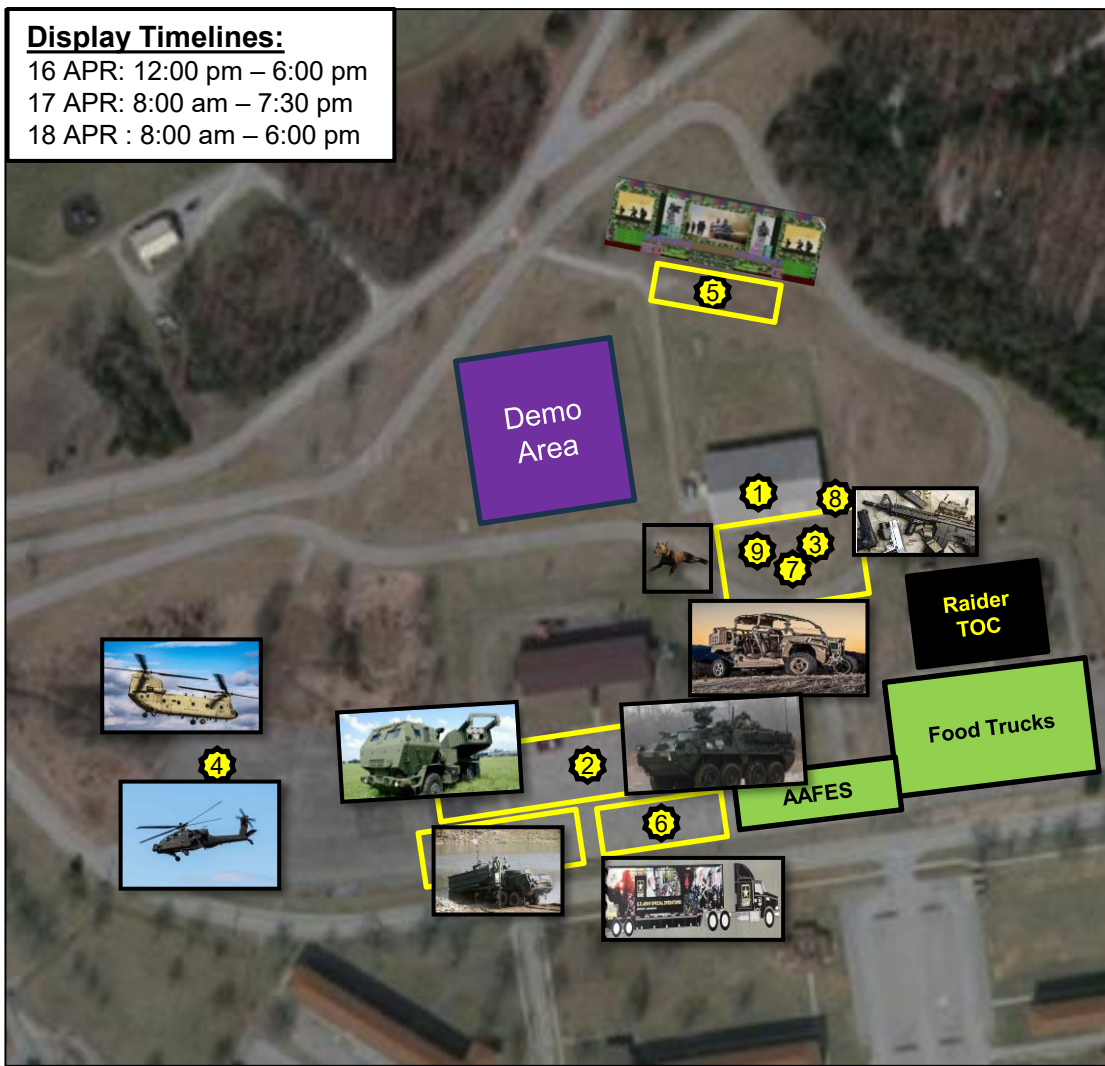

- 1 College Row**
ROTC Programs, NRTOC, AFROTC, USMA, USAREC
- 2 KY ARNG**
1x HIMARS, MATV, Stryker, JLTV, LMTV, HEMMT, M113, M1068
- 3 TSC**
Weapons Tables
- 4 MS/MO ARNG**
1x AH-64, 2x UH-60
- USAREC**
 - 1** Recruiting Tent – College Row
 - 5** Band Trailer / 10TH MTN Band
 - 6** USAREC Trailer / American Soldier Adventure
- 7 75th Ranger Regiment**
1x MRZR, Weapons Display
- 8 FKKY Veterinarian**
1x Diesel Dog

Static Display Layout

Be All You Can Be

101st CAB



1. AH-64



2. UH-60



KY ARNG



1. HIMARS



2. MATV



3. Stryker



4. HEMTT Fueler



5. HEMTT



6. M113



7. M1068



8. JLTV



TSC



1. Foreign Weapons



2. US Weapons



75th Ranger Regiment



1. MRZR



2. US Weapons





College Row Layout

Be All You Can Be



U.S. ARMY

- 2 BDE
- 3 BDE
- 4 BDE
- 5 BDE
- 6 BDE
- 7 BDE
- 8 BDE
- Other
- JROTC
- USACC HQs

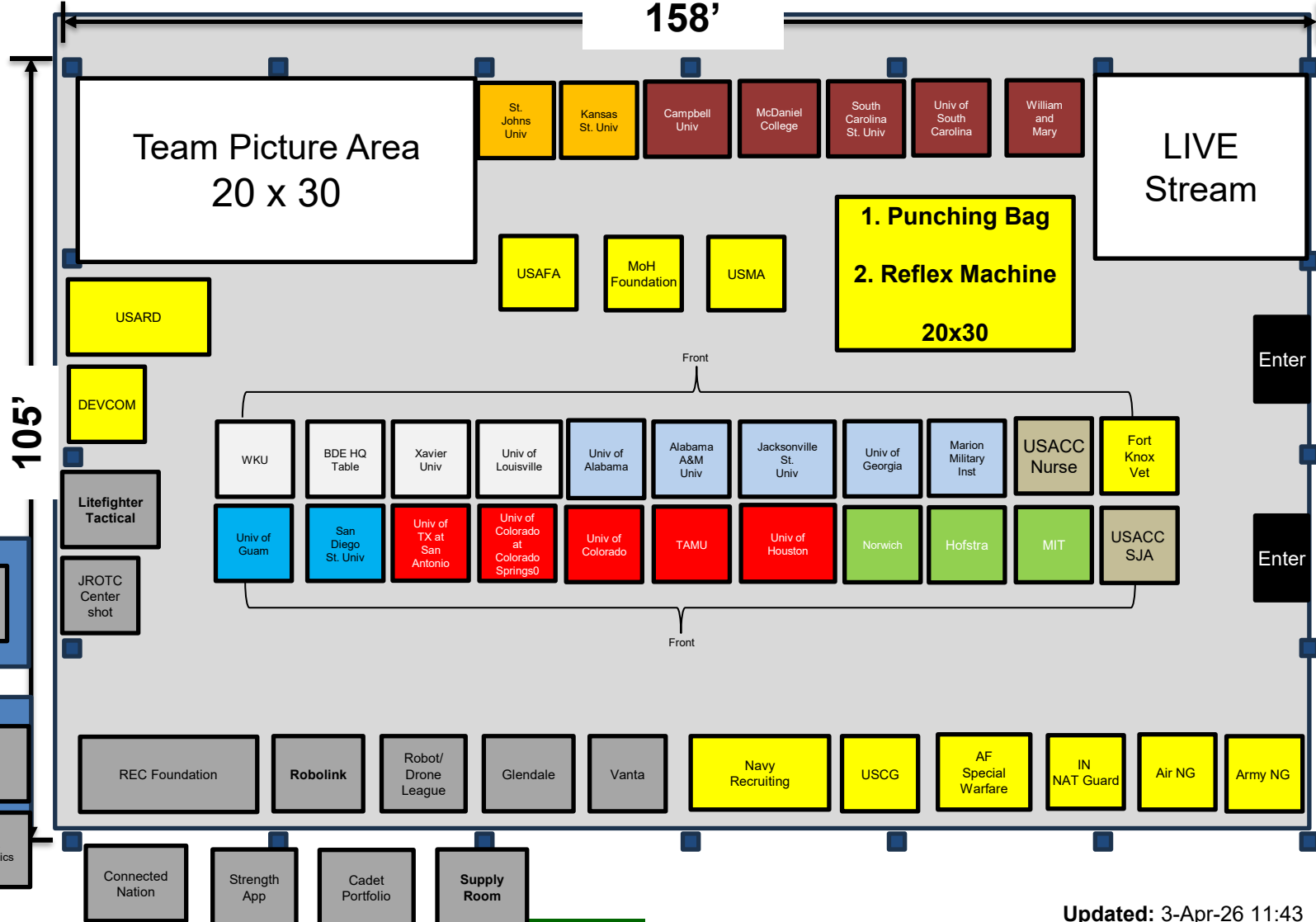



3rd Annual College Row Representation



Be All You Can Be

JROTC

1. Glendale
2. Centershot
3. VEX
4. REC Foundation
5. Robot/Drone League
6. Connected Nation
7. Vanta
8. Robolink
9. Strength App
10. Supply Room
11. Litefighter Tactical
12. Cadet Portfolio

2 BDE

1. **Norwich University**
2. Hofstra University
3. MIT

3 BDE

1. St. Johns University
2. Kansas State University

4 BDE

1. Campbell University
2. McDaniel College
3. South Carolina State University
4. University of South Carolina
5. William and Mary

5 BDE

1. University of Texas at San Antonio
2. University of Houston
3. **Texas A&M University**
4. University of Colorado
5. University of Colorado at Colorado Springs

6 BDE

1. University of Alabama
2. Alabama A&M University
3. Jacksonville State University
4. University of Georgia
5. **Marion Military Institute**

7 BDE

1. University of Louisville
2. Western Kentucky University
3. Xavier University
4. BDE HQ Table

8 BDE

1. University of Guam
2. San Diego State University

Other

USARD
USACC Nurse
USACC SJA
Vet Clinic
Navy Recruiting
Air Force Special Warfare
USMA
US Coast Guard
Army National Guard
Air National Guard
Indiana NG
United States Air Force Academy
Medal of Honor Foundation

DEVCOM

Leadership Excellence

Be All You Can Be

National Raider Challenge Competition

Ceremony Layouts



Leaders for Life

Opening Ceremony 5:45pm on 16 APR 25

Be All You Can Be

- Sequence of Events**
- 4:00: Music Starts
(Pop/Country/Rock/Hip-hop mix) (Band Set-Up)
 - 4:25: Begin moving teams to staging/line-up area. In order by school
 - 4:30: MC introduces 10th MTN Band
 - 4:30: AYW Band Begins
 - 5:00: Installation Retreat
 - 5:15: 30 min until ceremony begins announced
 - 5:25: MC begins crowd hype
 - 5:41: Arrival of Official Party (SMA/CG/CSM)
 - 5:42: 105mm Cannon Honors
 - 5:45: Presentation of Colors
 - 5:50: National Anthem
 - 5:55: Invocation
 - 6:00: Parade of Cadets
 - 6:50: CG's opening remarks
 - 6:55: Army Song
 - 7:00: Firework Display
 - 7:25-8:00: Music
 - 8:00: Nightly Shutdown

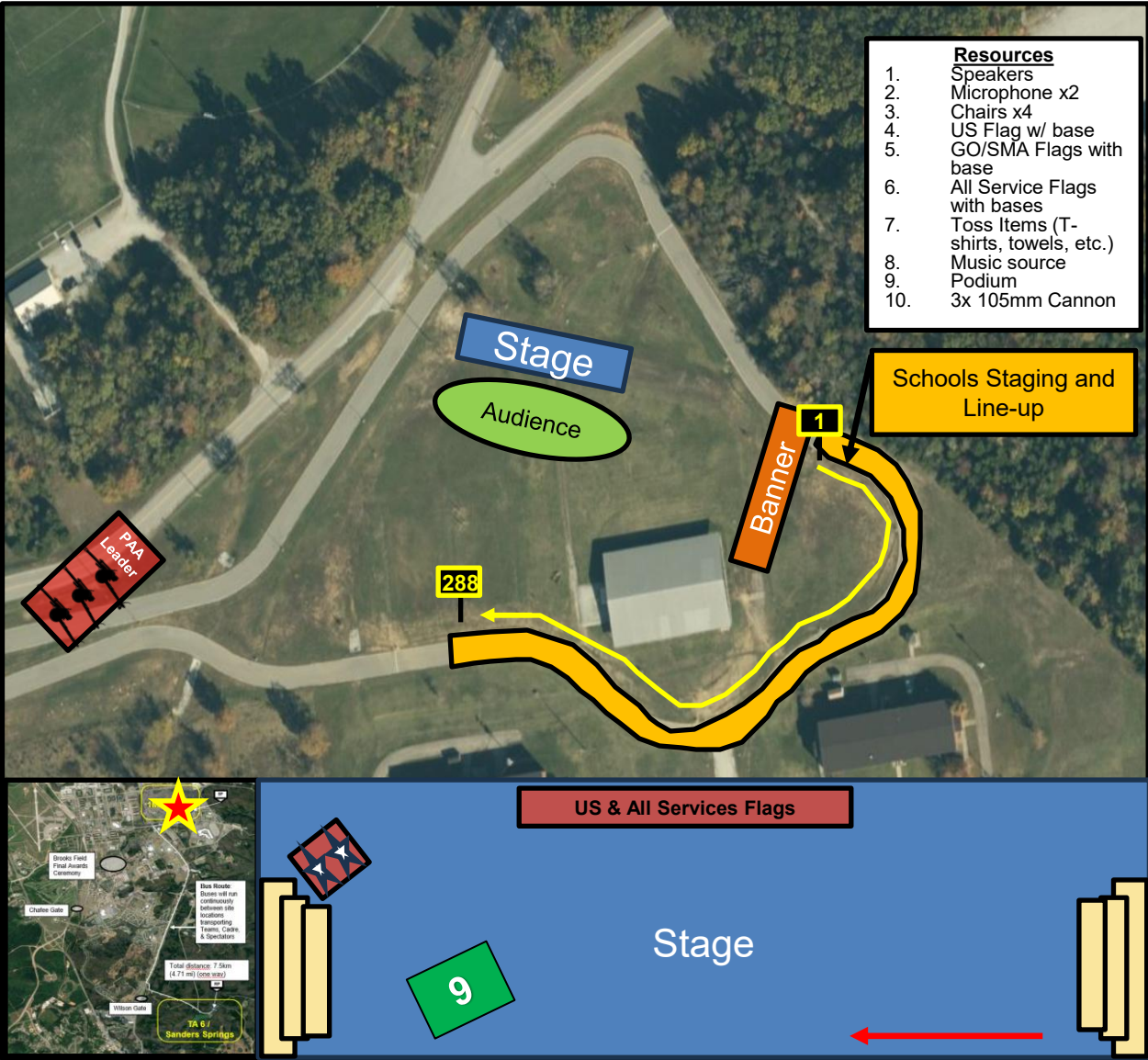



Challenge Award Ceremony 12:00pm 18 APR 25

Be All You Can Be

Sequence of Events

11:45(T): 15-minute warning / Lincoln HS Drum Corps play

11:50: MC crowd hype

12:00: CG's opening comments

12:05: Trophy presentation

12:05-12:20 Rope Bridge

Male

Female

Mixed

12:20-12:35 Gauntlet

Male

Female

Mixed

12:35-12:50 5K Run

Male

Female

Mixed

12:50-1:05 Cross Country Rescue

Male

Female

Mixed

1:05-1:20 Battle Fit Challenge

Male (Individual)

Female(Individual)

1:20-1:25 Physical Team Test

Male

Female

Mixed

1:25-1:35 Challenge Male Top 3 (CG/CSM)

1:35-1:45 Challenge Female Top 3 (CG/CSM)

1:45-1:55 Challenge Mixed Top 3 (CG/CSM)

1:55-2:05: Closing comments

Resources

1. Speakers
2. Microphone x2
3. Chairs x4
4. US Flag w/ base
5. GO Flags w/ base
6. Toss Items (T-shirts, towels, etc.)
7. Laptop
8. Music source
9. Podium
10. Tables x6

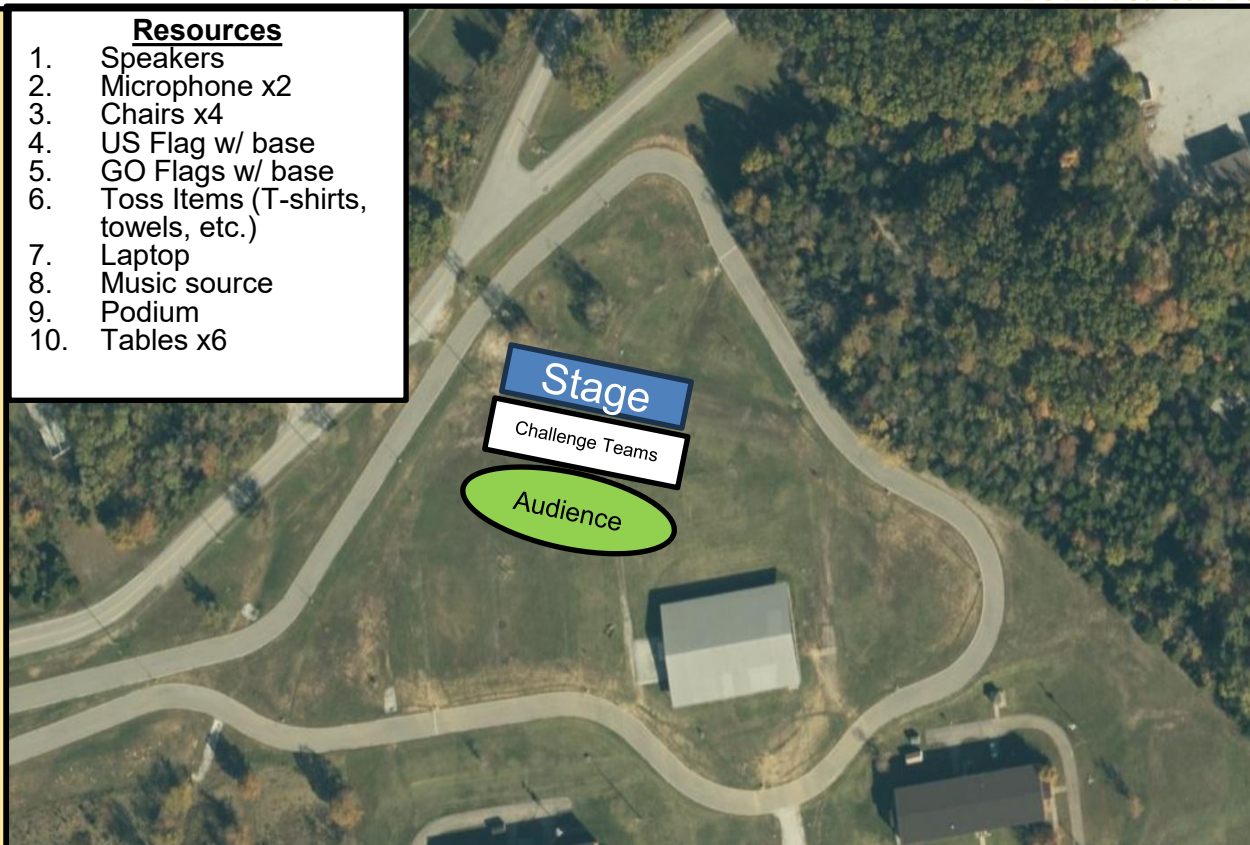

Masters/All Service Awards & Closing Ceremony

12:00pm 19 APR 25



Be All You Can Be

Sequence of Events

- 8:30: 105mm Cannon Emplacement
- 9:00: SNI Trophy Setup
- 10:00: Ultimate Raider Completed
- 11:00: Knockout a Bunker Demonstration
- 11:45: MC crowd hype
- 11:55: USMA Parachute Jump
- 12:02: CG's opening comments/Introduce Guest Speaker
- 12:05-12:10: Guest Speaker Comments
- 12:10: Trophy presentation

- 12:15-12:30: **Rope Bridge**
Male (M) & (AS)
Female (M) & (AS)
Mixed (M) & (AS)

- 12:30-12:45: **Gauntlet**
Male (M) & (AS)
Female (M) & (AS)
Mixed (M) & (AS)

- 12:45-1:00: **5K Run**
Male (M) & (AS)
Female (M) & (AS)
Mixed (M) & (AS)

- 1:00-1:15: **Cross Country Rescue**
Male (M) & (AS)
Female (M) & (AS)
Mixed (M) & (AS)

- 1:15-1:30 **Physical Team Test**
Male (M) & (AS)
Female (M) & (AS)
Mixed (M) & (AS)

- 1:30-1:45: **Battle Fit Challenge**
Male (M) & (AS Individual)
Female (M) & (AS Individual)
Mixed (M)

- 1:45-2:00: **Ultimate Raider**
Male (M) & (AS) (2 buddy Team)
Female (M) & (AS) CPT/Coach
Mixed (M) & (AS)

- 2:05-2:15: All-Service Male Top 3
- 2:15-2:25: Masters Male Top 3
- 2:25-2:35: All-Service Female Top 3
- 2:35-2:45: Masters Female Top 3
- 2:45-2:55: All-Service Mixed Top 3
- 2:55-3:05: Masters Mixed Top 3
- 3:10: CG's Closing Comments
- 3:20: Army Song

Resources

1. Speakers
2. Microphone x2
3. Chairs x4
4. US Flag w/ base
5. GO Flags w/ base
6. Toss Items (T-shirts, towels, etc.)
7. Laptop
8. Music source
9. Podium
10. Tables x6

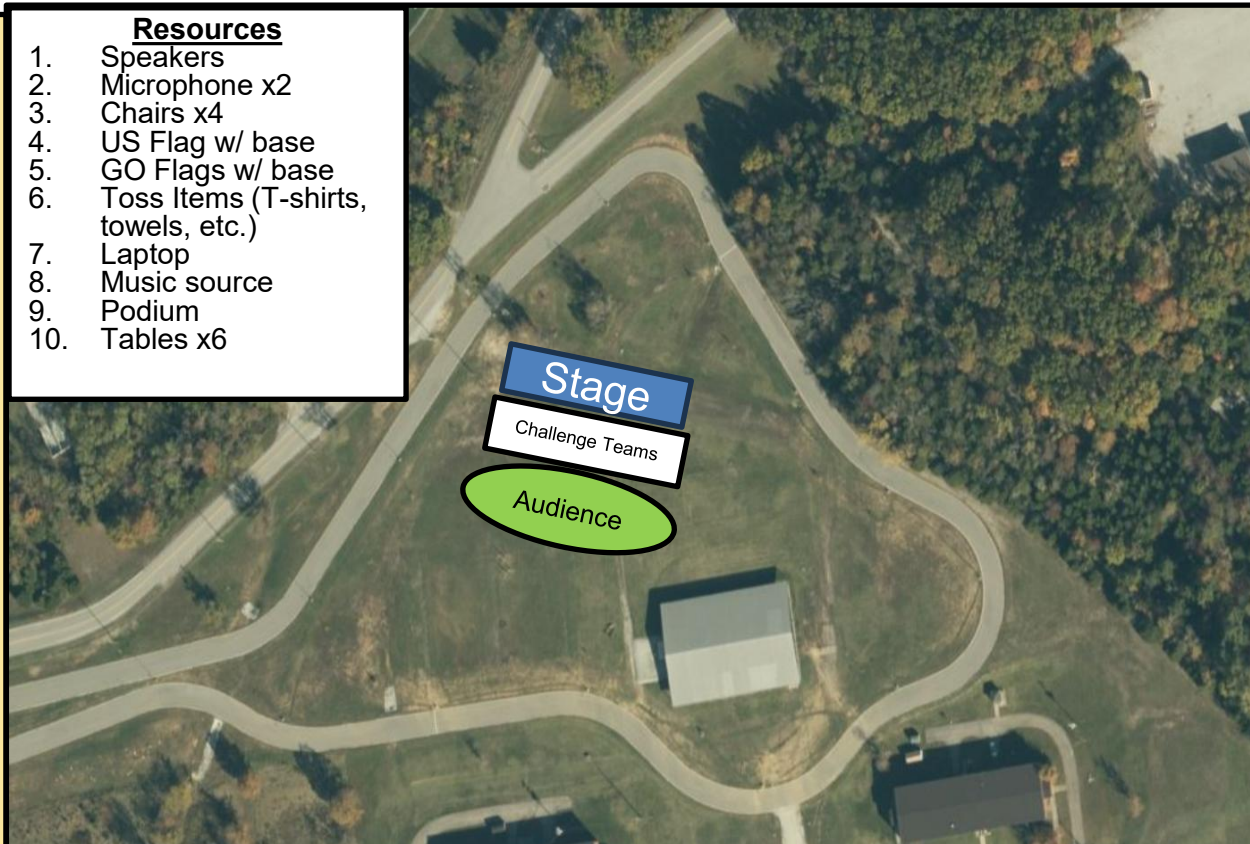



Leadership Excellence



Be All You Can Be

National Raider Challenge Competition

Logistical Support Overlay



Leaders for Life

Purpose: Billeting assignments for competitors.

Concept:

- Schools/Programs occupy and Barracks o/a 16 APR
- 2nd Brigade occupies 6011, 6017 (Navy/Marines) (150 M, 160 F) Barracks max = 357
- 3rd Brigade occupies 6010, 6015 (288 M, 171 F) T= 520
- 4th Brigade occupies 5936, 5937, 5938, 5939 (540 M, 354 F) Barracks max = 1,028
- 5th Brigade occupies 6552, 6555A, 6555B, 6557 (445 M, 316 F) Barracks max = 875
- 6th Brigade occupies 6546, 6547, 6548, 6550, 6551 (540 M, 354 F) Barracks max = 1,028
- 7th Brigade occupies 5919c, 5920, 5921, 5922 (475 M, 327, F) Barracks max = 922
- 8th Brigade occupies 6542A, 6542B (Air Force) (182 M, 112 F) Barracks max = 338
- Cadre occupies 1482, 1483, flex space 6578

Notes:

- Once registration is complete, G4 will finalize plan
- NO linen provided. Schools/Programs and participants will need to include sleeping materials within packing list.
- Disney Complex Barracks is 324 Bed Capacity per building.
- 6500 Complex Barracks is 220 Bed Capacity per building.



Phase III: Execution

Phase IV: Recovery

6 APR	11 APR	16 APR	16 APR	17-19 APR	19 APR	19 APR	20 APR
G4 develops Cadre / Cadet billeting plan	Receive Main Body and setup	Receive Teams	Opening Ceremony/ Fireworks	Challenge Division, Masters, All Service	Award Ceremony	Equipment Turn-in & Clear lanes	G4 starts clearing Cadre billeting / reception teams
Completed				<ul style="list-style-type: none"> Receive Teams Issue Billeting Assignment Provide Info on after hour Support Clear Teams/Cadre as required 			

Updated: 5-Apr-26 11:43



1- Mile Track & Disney Warrior Restaurants/Water Points

Be All You Can Be

Purpose: Identify feeding points, location to pick-up Meals-Ready-to-Eat (MREs), water points for competitors, and identify lunch/dinner options for families.

Concept:
Feeding locations:
 ★ **MWR (Breakfast)**
 BLDG **6018/6555B**, 0500-0800 (17-19 APR)
 Start set up 13 APR, Breakdown 20 APR
 3,000 breakfast meals per day (Vouchers)
 ★ **AAFES Food Trucks (Lunch, Dinner) "Cash/Credit"**
JROTC Parking Lot (10-12 Food Trucks)
Gauntlet & 5K (1-2 Food Trucks)
 - Gen. Pho Vietnamese Kitchen
 - Coffee's & Cream
 - Boujee Brown Box
 - Lady G's Southern Cuisine
 - Headquarters BBQ
 - Trap House Chicken and Ribs
 - Cox Catering
 - Snow Dogs
 - Padrinos
 - Family Fun Ice Cream
AAFES Special Hours of Operations
 - Wilson Express Thursday-Saturday 0600-2400
 - Wilson Starbucks Thursday-Saturday 0600-2000, Sunday 0600-1400
 - Main Exchange Food Court Thursday-Saturday 0800-2000, Sunday 1000-1800
 - Burger King Friday and Saturday 0700-2000
 - Taco Bell Friday and Saturday 0900-2000
Pop-Up Tent Store - 10x30 tent (JROTC HQ)
 - 0700-2200 Friday and Saturday
 - 0700-1200 Sunday (Look to push until after award ceremony)
 - 1000-1600 we will set up a smaller pop-up at 1-mile track T-shirts, Sweatshirts, Cups Water Bottles, Hats, magnets, decals, etc., with the Raider Challenge and Fort Knox logo's, Umbrella, rain ponchos, camping stools, first aid kits, Beverages, Snacks Candy, energy Drinks, etc.



Concept (cont.):
Water Points x4 (Spigots Sites)
 - WP1: 16SEG9347097223
 - WP2: 16SEG9359996371
 - WP3: 16SEG9300796269
 - WP4: 16SEG9284296903
 - WP5: 16SEG9376496567
Water Cans/Jugs (20 per location)
 - Cross Country Rescue (CCR)
 - Physical Team Test (PTT)
 - Battle Fit
 - 1 Rope Bridge
 - Gauntlet
 - 5K
 * Water Points will be marked and easily identifiable

★ **Meals Ready to Eat (MRE)**
 - MRE Issue Point by G4 Team
 - FY24: 4884 / FY25: 7133
 - MREs on-hand (9216 MREs, MORES 312, KOSHER 444)

Notes:
 - Disney Barracks and 6500 Series have potable water sources
 - Main Water Point located at grid 16SEG9405893917 (vic Wilson Road) for replenishment operations
 - Water Points will be checked twice a day
 - Schools/Programs will use Gov't Unit Travel Cards (GUTC) to purchase meals for Cadets.

Phase III: Execution

Phase IV: Recovery

6 APR	11 APR	16 APR	16 APR	17-19 APR	19 APR	19 APR	20 APR
G4 develops Cadre / Cadet billeting plan	Receive Main Body and setup	Receive Teams	Opening Ceremony/ Fireworks	Challenge Division, Masters, All Service	Award Ceremony,	Equipment Turn-in & Clear lanes	G4 starts clearing Cadre billeting / reception teams

65 Completed
★ Warrior Restaurants
★ Food Trucks
★ MRE Issue

- Receive Teams
- Issue Billeting Assignment
- Provide Info on after hour Support
- Clear Teams/Cadre as required

1 Mile Track Barriers & Road Guards



Concept 16-19 1-Mile Track Road Guards & Barriers:

- Control vehicle access / protect pedestrian traffic
- 0800-UTC, 10x road guards & multiple barriers will be present until conclusion of all events conducted at the 1 Mile Track

1 Mile Track - Food Trucks

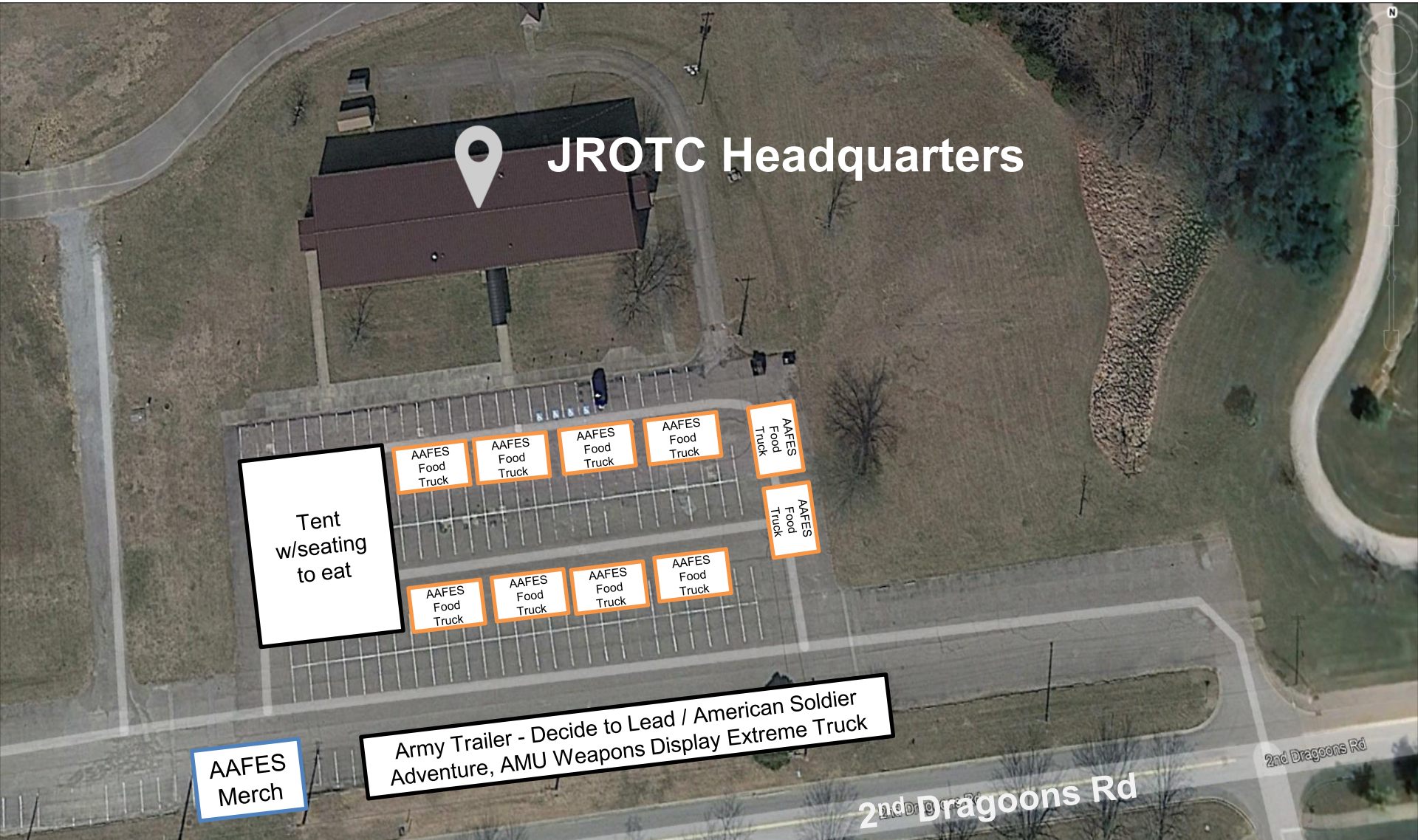

Concept 16-19 APR 1-Mile Track Road Food Trucks:

- Provide quality food choices to all personnel attending Raider Challenge
- 0800-UTC, 12-14 food trucks will be in front of the JROTC Headquarters



1- Mile Track & Disney Warrior Restaurants/Water Points



Be All You Can Be

Purpose: Identify feeding points, location to pick-up Meals-Ready-to-Eat (MREs), water points for competitors, and identify lunch/dinner options for families.

Concept:
Feeding locations:
 ★ **MWR (Breakfast)**
 BLDG **6018/6555B**, 0500-0800 (17-19 APR)
 Start set up 13 APR, Breakdown 20 APR
 3,000 breakfast meals per day (Vouchers)
 ★ **AAFES Food Trucks (Lunch, Dinner) "Cash/Credit"**
JROTC Parking Lot (10-12 Food Trucks)
Gauntlet & 5K (1-2 Food Trucks)
 - Gen. Pho Vietnamese Kitchen
 - Coffee's & Cream
 - Boujee Brown Box
 - Lady G's Southern Cuisine
 - Headquarters BBQ
 - Trap House Chicken and Ribs
 - Cox Catering
 - Snow Dogs
 - Padrinos
 - Family Fun Ice Cream
AAFES Special Hours of Operations
 - Wilson Express Thursday-Saturday 0600-2400
 - Wilson Starbucks Thursday-Saturday 0600-2000, Sunday 0600-1400
 - Main Exchange Food Court Thursday-Saturday 0800-2000, Sunday 1000-1800
 - Burger King Friday and Saturday 0700-2000
 - Taco Bell Friday and Saturday 0900-2000
Pop-Up Tent Store - 10x30 tent (JROTC HQ)
 - 0700-2200 Friday and Saturday
 - 0700-1200 Sunday (Look to push until after award ceremony)
 - 1000-1600 we will set up a smaller pop-up at 1-mile track T-shirts, Sweatshirts, Cups Water Bottles, Hats, magnets, decals, etc., with the Raider Challenge and Fort Knox logo's, Umbrella, rain ponchos, camping stools, first aid kits, Beverages, Snacks Candy, energy Drinks, etc.



Concept (cont.):
Water Points x4 (Spigots Sites)
 - WP1: 16SEG9347097223
 - WP2: 16SEG9359996371
 - WP3: 16SEG9300796269
 - WP4: 16SEG9284296903
 - WP5: 16SEG9376496567
Water Cans/Jugs (20 per location)
 - Cross Country Rescue (CCR)
 - Physical Team Test (PTT)
 - Battle Fit
 - 1 Rope Bridge
 - Gauntlet
 - 5K
 * Water Points will be marked and easily identifiable

★ **Meals Ready to Eat (MRE)**
 - MRE Issue Point by G4 Team
 - FY24: 4884 / FY25: 7133
 - MREs on-hand (9216 MREs, MORES 312, KOSHER 444)

Notes:
 - Disney Barracks and 6500 Series have potable water sources
 - Main Water Point located at grid 16SEG9405893917 (vic Wilson Road) for replenishment operations
 - Water Points will be checked twice a day
 - Schools/Programs will use Gov't Unit Travel Cards (GUTC) to purchase meals for Cadets.

Phase III: Execution

Phase IV: Recovery

6 APR	11 APR	16 APR	16 APR	17-19 APR	19 APR	19 APR	20 APR
G4 develops Cadre / Cadet billeting plan	Receive Main Body and setup	Receive Teams	Opening Ceremony/ Fireworks	Challenge Division, Masters, All Service	Award Ceremony,	Equipment Turn-in & Clear lanes	G4 starts clearing Cadre billeting / reception teams

 Completed
★ Warrior Restaurants
★ Food Trucks
★ MRE Issue

- Receive Teams
- Issue Billeting Assignment
- Provide Info on after hour Support
- Clear Teams/Cadre as required



1-Mile Track & Disney Refuse Services

Be All You Can Be

Purpose: Refuse container locations.

Concept:

- Confirm requirements with Garrison and Logistics Readiness Center (LRC) NLT 13 JAN
- Refuse set 08 APR
- Locations as follow:
 - 16x Trash Bins at Disney North (vic of 5916, 5920, 5922, 5938, 5937)
 - 11x Trash Bins at Disney South (vic of Warrior Restaurant (WR) 6012, WR 6018, 6011, 6017)
 - 2x Trash Bins at Command Offices (COFs) (vic of 5950, 5951)
 - 2x Trash Bins at Kilianski Sport Complex Parking Lot
 - 13x Trash Bins vic 1-Mile Track (Corner of UPTON Rd, vic of Callan Hall, and JROTC HQs)
 - 12x Trash Bins vic 6500 Series Block (6555, 6550, 6552, 6546, 6542, 6548)
 - 1x Trash Bin vic Forrest Hill

- Service:**
- Thurs (16 APR) - 1x Pickup/Day
 - Fri (17 APR) - 2x Pickup/Day, 1400 Block
 - Sat (18 APR) - 2x Pickup/Day, 1400 Block
 - Sun (19 APR) - 1x, everything 2x 1-mile



Phase III: Execution

Phase IV: Recovery



Completed

- Roving Services will continue throughout the day 17-19 APR
- Evening all will be reset for the next day



1-Mile Track & Disney Latrines & HWS Services



Be All You Can Be

Purpose: Latrine and Hand-Wash Stations (HWS) locations

Concept:
Portable Latrines and

- Hand-Washing Stations (HWS)**
- Portable Latrines/ HWS set o/a 08 APR
 - Locations as follow:
 - 10x Latrines/ 2x HWS at Disney North
 - 16x HWS at WR6018/WR6555 (ISO MWR)
 - 20x Latrines/ 4x HWS at Upton (RV Park)
 - 20x Latrines/ 4x HWS at Gauntlet
 - 10x Latrines/ 2x HWS at Tent Area (vic Wilson Rd)
 - 10x Latrines/ 4x HWS at Kilianski
 - 6x Latrines/ 2x HWS North of 1-Mile Track
 - 20x Latrines/ 6x HWS West of 1-Mile Track
 - 10x Latrines/ 2x HWS vic 6555 Bus Stop
 - 20x Latrines/ 4x HWS at BLDG 6519
 - 20x Latrines/ 4x HWS at 5K
 - 4x Latrines/ 1x HWS at Ultimate Raider
 - 20x Latrines/ 6x HWS at JROTC ISO AAFES Food Trucks

Service: Portable Latrines & HWS will be serviced 2x a day



Phase III: Execution

Phase IV: Recovery

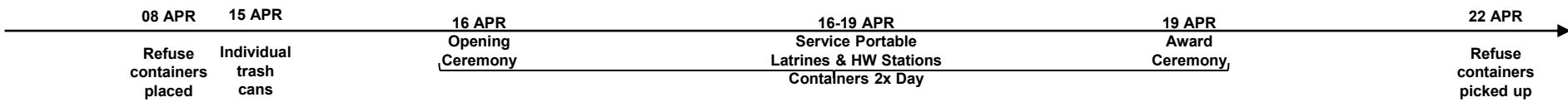

- Roving Services will continue throughout the day 17-19 APR
- Evening all will be reset for the next day

Completed

Updated: 3-Apr-26 11:43
One ROTC

Transportation



Purpose: Bus transportation routes for competitors and spectators during the event.

Concept:

- Execute Gator Training at FT Knox 7-8 APR
- Receive 4x Commercial buses & 2x Handicap for spectators / non competitors (Receive buses on **15 APR**)
- Execute spectator Bus Driver Route Recon **15 APR**
- Lane OIC / USACC Staff will sign for box trucks & STRs from CST MP on **10 APR**
- Route Identified:
 - **Blue Line:** (Spectators) Round Robin for spectators & non-competitors (**0600-1830**)
- **Buses start point is Bus Hub vicinity BLDG #6555**
 - ❖ Bus Stop 1: 5K
 - ❖ Bus Stop 2: Gauntlet (Vicinity BLDG #6018)
 - ❖ Bus Stop 3: Nelson Clinic (Vicinity BLDG #5949)
 - ❖ Bus Stop 4: CST Medical WH (Vicinity BLDG #5914)
 - ❖ Bus Stop 5: Bus Hub (Vicinity BLDG# 6555B)

Notes:

- POVs and JROTC program-chartered transportation buses are authorized at 1-mile track only. **Competitors & Spectators will not be allowed to drive to 5K or Gauntlet; to access these events competitors will walk and spectators must walk or use buses at Bus HUB.**
- Bus Hub and bus stops will be marked and easily identifiable
- Cadet Command Transportation Assets: Additional STRs are required to support RC mission after utilizing all GSA vehicles assigned to HQs, 1BDE, and 7BDE (25 required)
- 6x Gators (all for medical support)





RV Wastewater Disposal Services

Purpose: Locations of RV wastewater treatment plant.

Primary Location:
 Hardin County Water District #1 at Fort Knox Wastewater Treatment Plant (WWTP)
 - Open 7-days a week
 - Hours of Operations 0730-1700
 - 7207 S Carolina St, Fort Knox KY 40121
 - Phone Number: (502) 942-6020

Alternate Location:
 Camp Carlson
 - 9210 US-60, Muldraugh, KY 40155
 - Phone Number: 502-624-4836

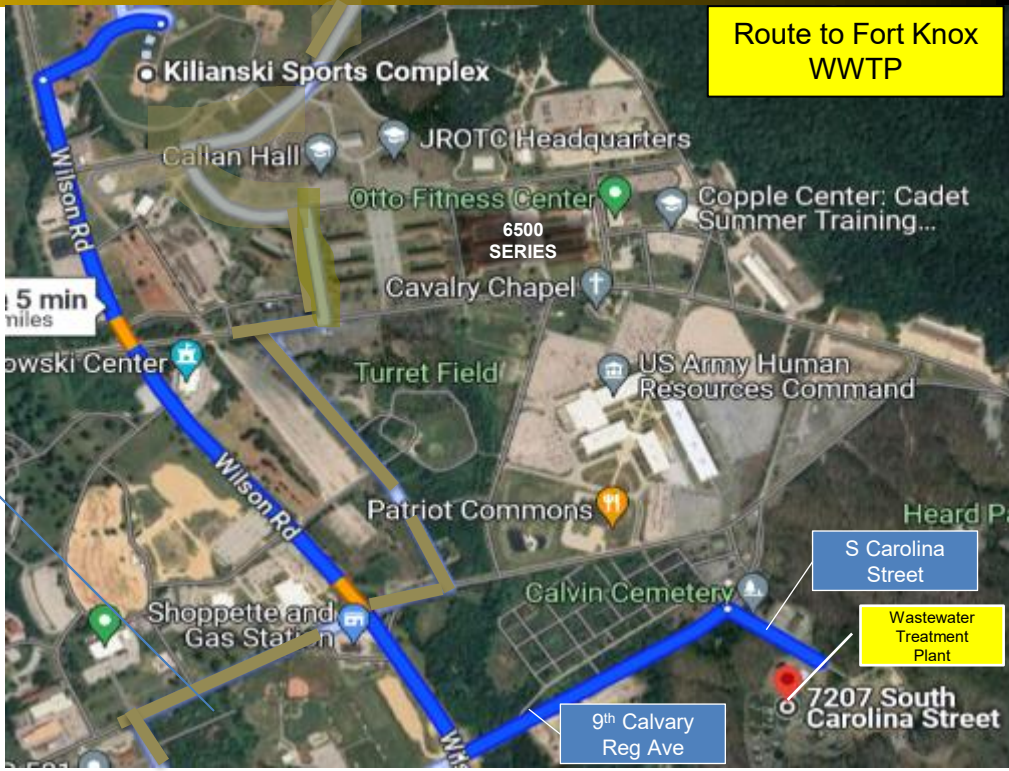
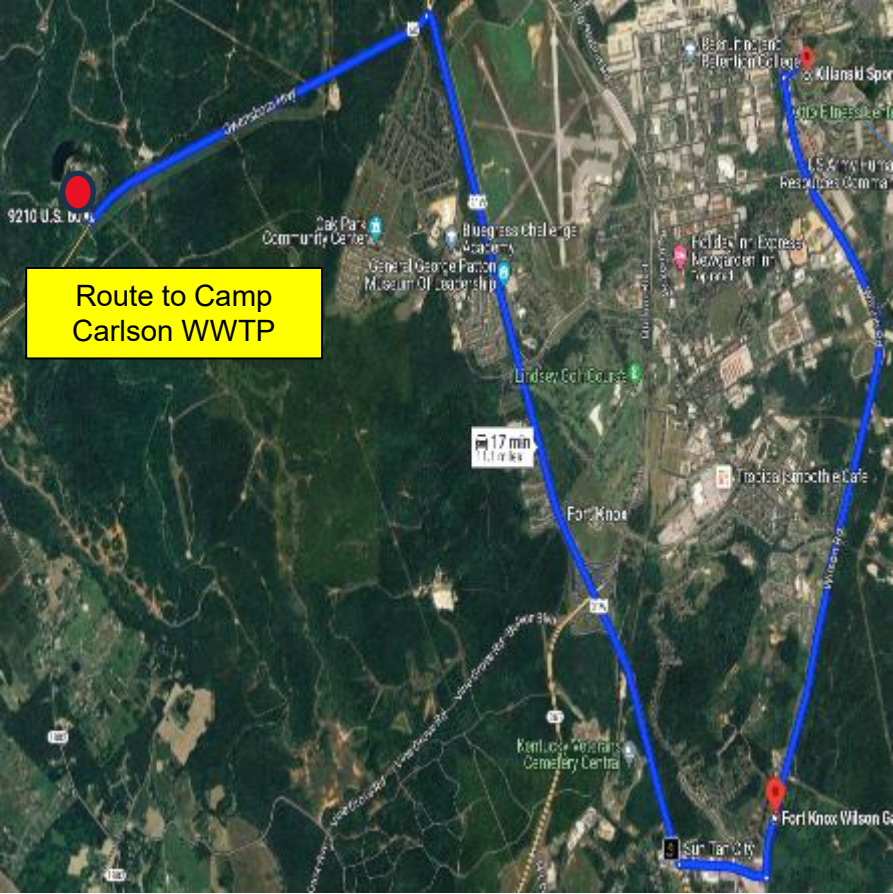



Leadership Excellence



Be All You Can Be

National Raider Challenge Competition

Medical Support Overlay



Leaders for Life



Raider Concept of Medical Support

Be All You Can Be

American Red Cross

- 5 Medics

EMS Ambulance

- On-site 0700-1900

UTV Transport

- 4 UTVs to transport non-litter patients

Medical Resupply

- Pre-built Push packs upon request

Medical Transport

- 2 Vans to transport Cadets with Chaperone to Urgent Care
- Request submitted from ARC to Driver

AEDs-16

- 1 at ARC
- 2 at each lane (12)
- 1 in Ambulance
- 2 on reserve

Fort Knox Fire

- Litter capable UTV
- Medical Trailer

BDE Surgeon / BNC

- 1 Medical rep at each lane



Ground Evacuation

- One Ambulance is onsite at the 1-mile track.
- 4 Utility Vehicles (UTVs) will be available at the 1-mile track to CASEVAC personnel to ARC / EMS.
- BDE Surgeon / BNC at each lane to triage patients.

Medical Treatment: Ground

- Baptist Health Hardin- 14 miles / 25 minutes from 1 mile track
- U of L Hospital- 41 miles / 47 minutes from 1 mile track

Medical Treatment: Civilian Air Methods

- Baptist Health Hardin- 14 miles / 20 minutes from 1 mile track
- U of L Hospital- 41 miles / 35 minutes from 1 mile track

Cadre Sick Call

- 10-20 APR- On call to Surgeon Cell at 210-823-6799, available to be seen at IRAHC or Urgent care after coordination with MAJ Hensel

Medical Limitations

- Spectators cannot be seen by military medical assets unless it is Life / Limb / Eyesight
- UTVs do not move littered patients
- No dedicated Aeromedical assets = slightly longer response time due to not having dedicated air assets

HLZ

- Only Godman Army Airfield is to be used (Air MEDEVAC is taken from airfield by Air Methods)

American Red Cross

- Will provide basic medical treatment at 1-Mile Track from 1100-2000 16 APR, 0700-1800 17-18 APR.

- BDE Surgeon / BNC 
- Ambulance 
- UTV 

American Red Cross 



Ultimate Raider Medical COS



Be All You Can Be

Who : 6th Brigade SROTC
What: Ultimate Raider
Where: Fort Knox, KY
When:
OIC/NCOIC:

Key Tasks:

1. Continuous 4.2 mile run with equipment
2. 4 integrated events with critical thinking
3. Equipment inspections

Conditions:
 The Ultimate Raider will be executed in 5 waves of 5 teams. Two graders located at each obstacle and timekeepers at start/finish. Event executed as a full team (24 Teams)

Standards:

1. Teams from the top 5 Masters and top 3 All-Service Male, Mixed, and Female Sub-Divisions will be selected to compete in the Ultimate Raider (24 total teams).
2. The Ultimate Raider results will be tabulated into the competing teams overall scoring totals. This event is no longer weighted higher than Saturday events.
3. Teams will be given their equipment and 30 min to create a load plan for the event.
4. Teams navigate a 4.2-mile cross country course with 102.2 lbs of equipment and 4 grueling events to which each team member must traverse.
5. Teams will use critical thinking skills to complete obstacles with the equipment provided. Teams must start and finish with all equipment.
6. At the completion of the course, the time will stop for the team, and they will move to a nearby staging area to complete a final equipment layout.
7. Penalties will be assessed for failure to complete an obstacle, not finishing with all members of your team, and not having all of your equipment after you cross the finish line.

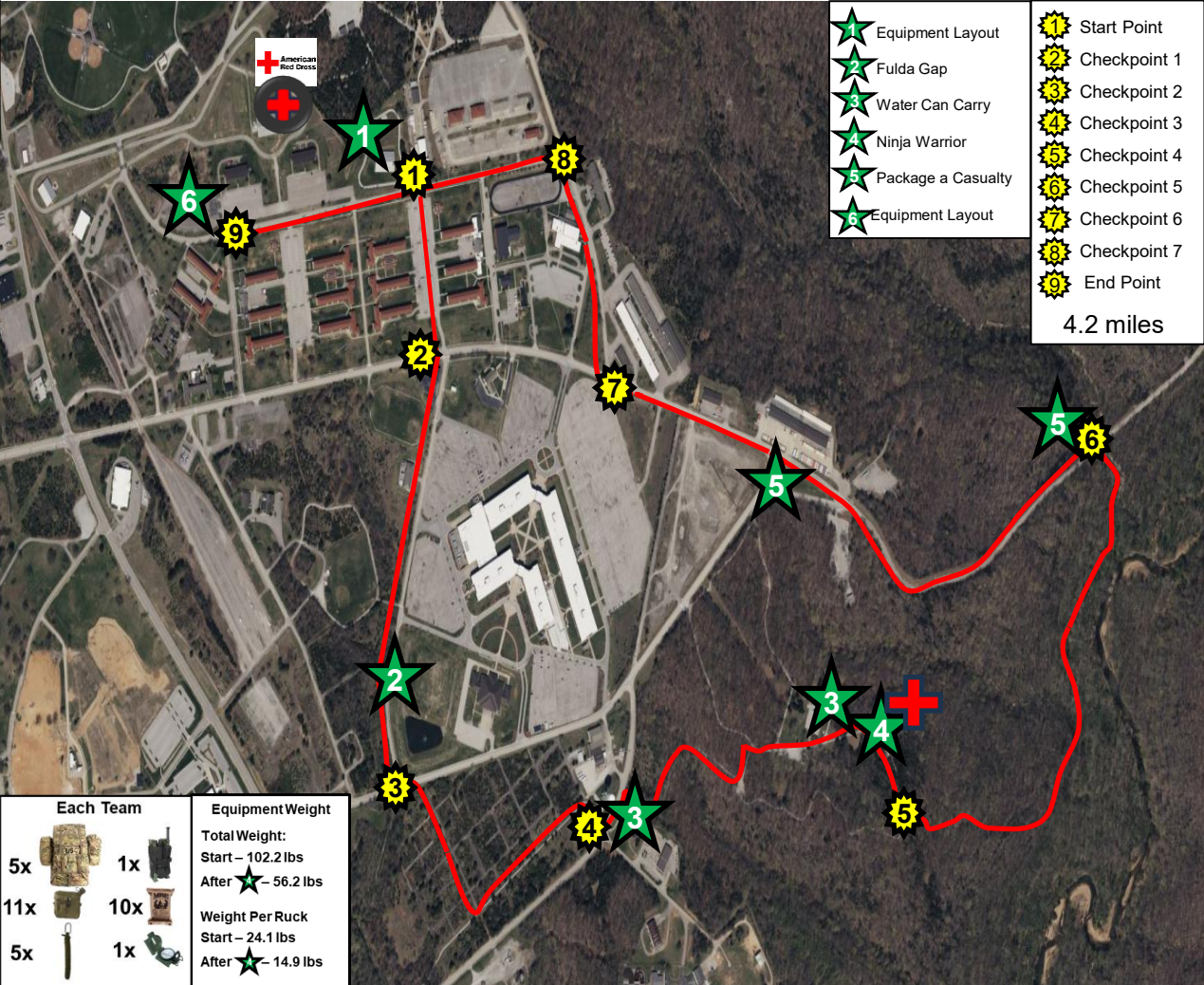

Each Team		Equipment Weight	
5x		1x	
11x		10x	
5x		1x	
Total Weight:		Start - 102.2 lbs	
		After ★ - 56.2 lbs	
Weight Per Ruck		Start - 24.1 lbs	
		After ★ - 14.9 lbs	

	0700	0730	0800	0830	0900	0930	1000	1030	1100	1130	1200	1230	1300	1330	1400	1430	1500	1530	1600	1630	1700	1730	1800	1830	1900	
19 APR	Team Trans	Equip Layout	Wave #1		Wave #2		Wave #3		Wave #4		Wave #5															
										Award Ceremony								Teams Depart								

Updated: 3-Apr-26 11:43



Responder Sequence

Be All You Can Be

Raider Challenge TOC Monitoring NET

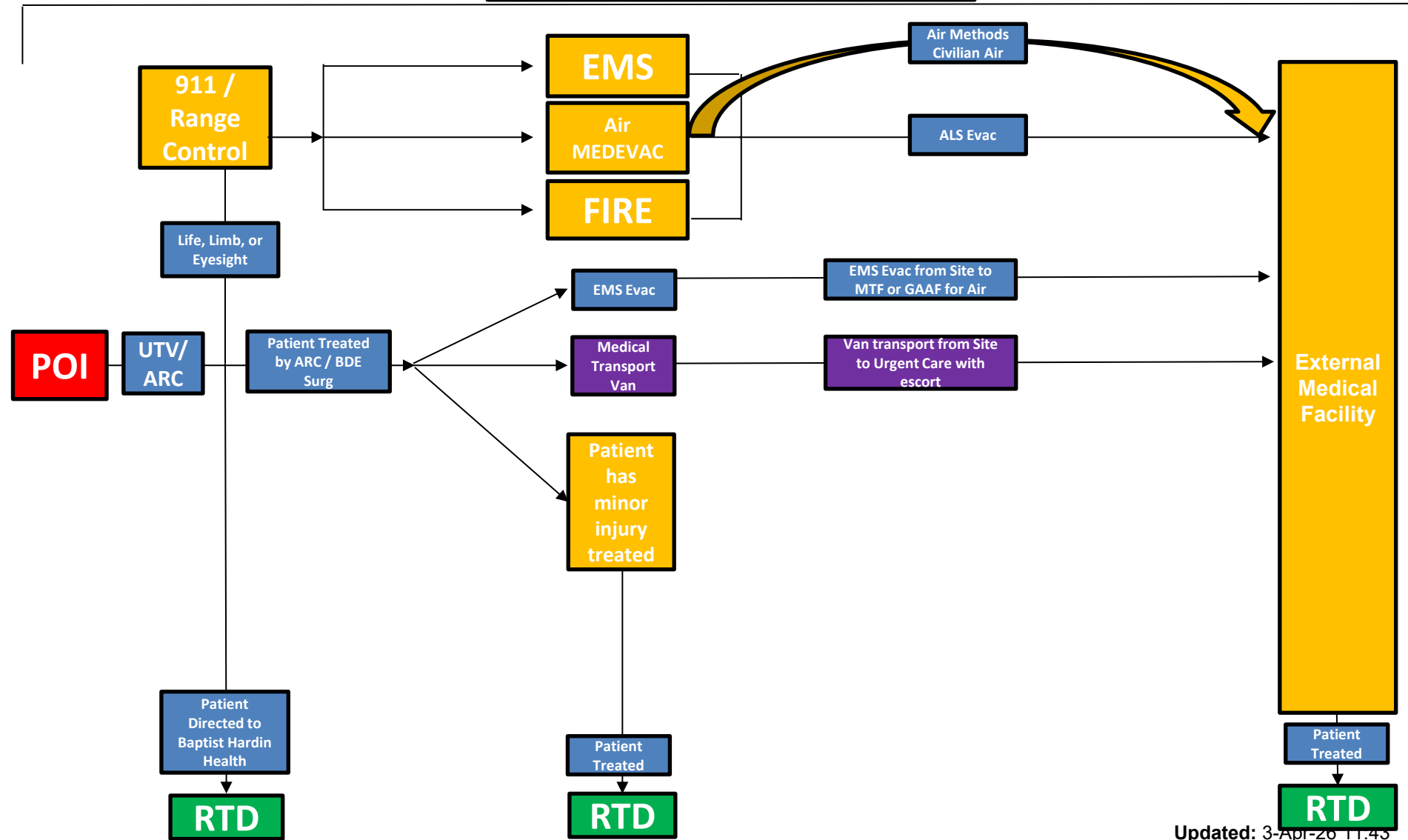



EMS Assets

On Post: 3 Ambulances

- 1 ambulance- one dedicated at 1-mile track. UTVs will be at the 1-mile track to assist with movement to the Ambulance on site. Two installation ambulances on call staged behind Ireland Army Health Clinic.

Within 10 miles of Ft. Knox: 7 Ambulances

- One staged outside post off HWY 60 in Meade County that is on call
- Six Hardin County EMS on call supporting Hardin County

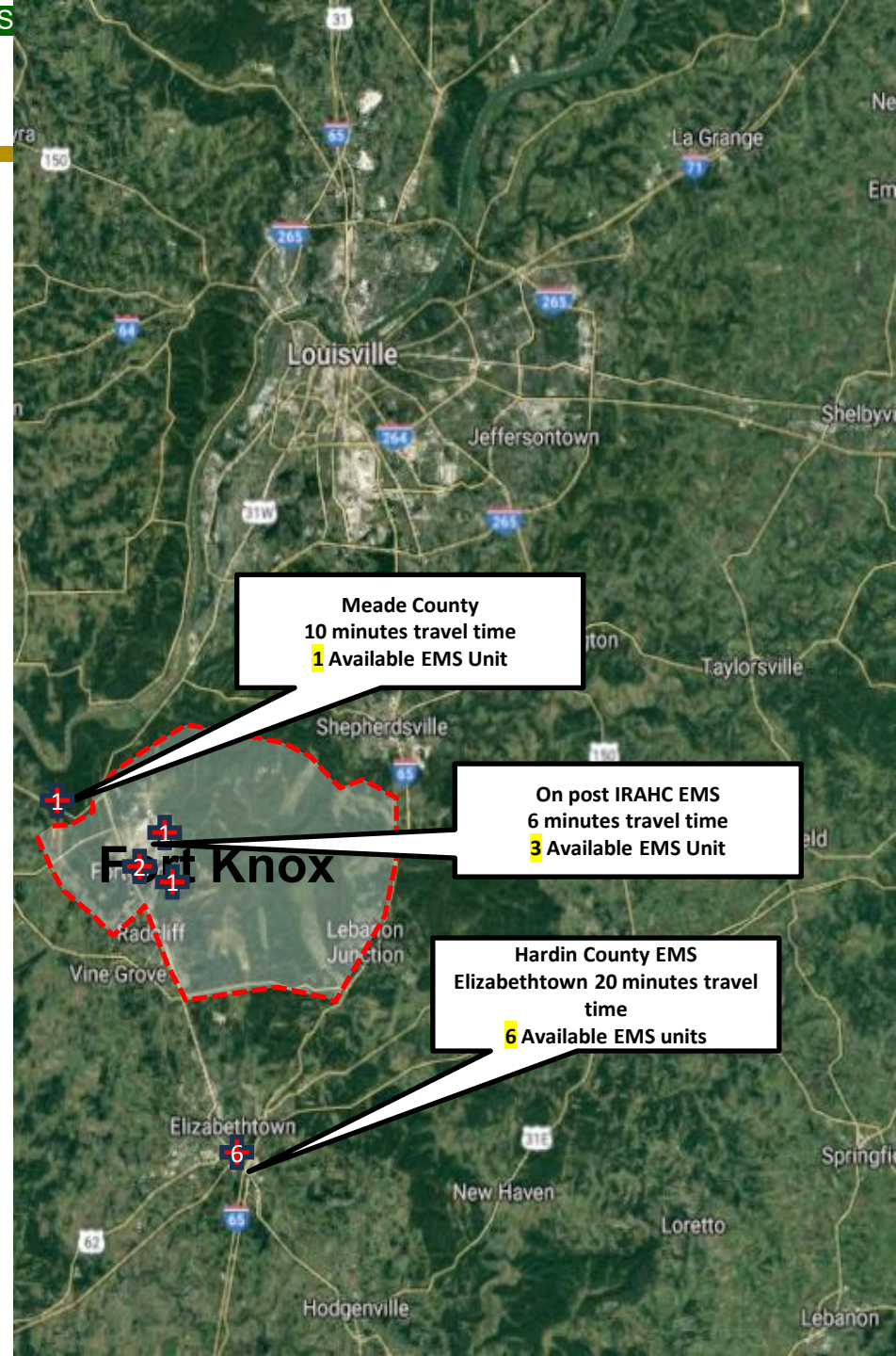



Medical Facilities

If its an emergency, call 911. Inform dispatch where you're on post

Be All You Can Be

On Post:

- Non-urgent care- American Red Cross located at the 1-mile track (1). UTVs will be at the 1-mile track to assist with movement to the Ambulance on site.
- Urgent care on post- Call 911, inform dispatch where you're on post.

Within 10 miles of Ft. Knox:

- [Urgent Care 1- Radcliff Urgent Care Clinic](#) 0830-2000 M-F / 0830-1800 Weekends
- [Urgent Care 2- Baptist Health Urgent Care-Radcliff](#) 1000-2130 M-Sat / 1400-2130 Sunday
- [Behavioral Health 1- Lincoln Trail Behavioral Health System](#)- 24 Hours/ 7 Days a week
- [Pharmacy 1- Radcliff Pharmacy](#)- 0900-1800 M-F / Closed on Weekends
- [Pharmacy 2- Walgreens](#)- 0800-2100 Tue-Fri / 0900-1800 Sat / 1000-1800 Sun
- [Pharmacy 3- Walmart Pharmacy](#)- 0600-2300 Daily

Up to 25 miles from Ft. Knox:

- [Urgent Care 3- Rapid Relief Urgent Care](#)-0800-2000 M-F / 0900-1700 Sat / 1200-1700 Sun
- [Urgent Care 4- Baptist Health Urgent Care](#)- Elizabethtown 1000-2130 M-Sat / 1400-2130 Sun
- [Emergency Room 1- Baptist Health Hardin Emergency Department](#)- 24 Hours/ 7 Days a week
- [Pharmacy 4- CVS](#)- 24 Hours/ 7 Days a week

When to go off post:

- If you or your child have a simple injury that does not require an ambulance ride to the hospital. Visit the American Red Cross Tent or Drive to one of the local medical facilities.
- If unsure, go to one of the ambulances and ask them if you should go to the hospital.
- If in need of medical help, get the attention of a UTV or ambulance.
- If you call 911, tell them where you are on Fort Knox. There is also two installation ambulances that can transport to local medical facilities if the need is urgent.
- If an ambulance or air medical asset is used, private insurance will be billed.

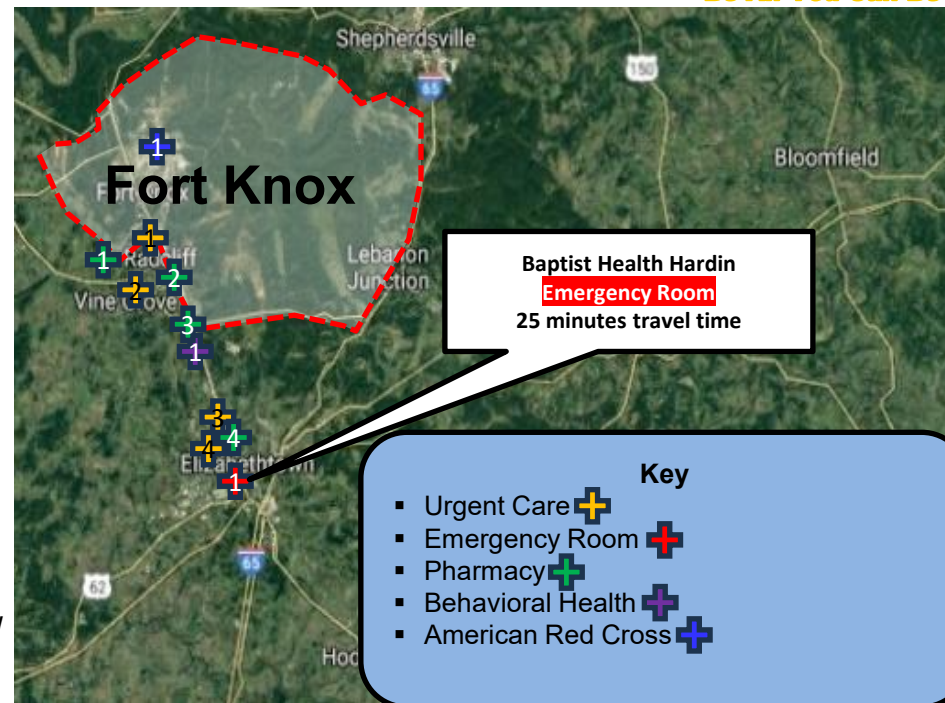

Medical Limitations:

- Parents / Spectators / Coaches cannot be seen by military medical assets unless it is Life / Limb / Eyesight
- UTVs do not move littered patients (patients that can't walk)
- No dedicated air medical assets = 1 local aircraft available (Air Methods) Insurance is billed if air is utilized.



Medical Facilities

U.S. ARMY If its an emergency, call 911. Inform dispatch where you're on post

On Post:

- 3 ambulances- one covering 1-mile track (1), 2 centrally located on post. UTVs will be at the 1-mile track to assist with movement to the Ambulance on site. **American Red Cross will be staged at the 1-mile track.**

Within 10 miles of Ft. Knox:

- Urgent Care 1- Radcliff Urgent Care Clinic 0830-2000 M-F / 0830-1800 Weekends
- Urgent Care 2- Baptist Health Urgent Care-Radcliff 1000-2130 M-Sat / 1400-2130 Sunday
- Behavioral Health 1- Lincoln Trail Behavioral Health System- 24 Hours/ 7 Days a week
- Pharmacy 1- Radcliff Pharmacy- 0900-1800 M-F / Closed on Weekends
- Pharmacy 2- Walgreens- 0800-2100 Tue-Fri / 0900-1800 Sat / 1000-1800 Sun
- Pharmacy 3- Walmart Pharmacy- 0600-2300 Daily

Up to 25 miles from Ft. Knox:

- Urgent Care 3- Rapid Relief Urgent Care-0800-2000 M-F / 0900-1700 Sat / 1200-1700 Sun
- Urgent Care 4- Baptist Health Urgent Care- Elizabethtown 1000-2130 M-Sat / 1400-2130 Sun
- Emergency Room 1- Baptist Health Hardin Emergency Department- 24 Hours/ 7 Days a week
- Pharmacy 4- CVS- 24 Hours/ 7 Days a week

Up to 50 miles from Ft. Knox:

- Emergency Room 2- University of Louisville Hospital (Level 1 Trauma Center). 45 miles, approximately 45 min drive from post. Open 24 Hours/ 7 Days a week
- Norton Childrens Hospital 1- Treatment for anyone under the age of 18. 46 miles, approximately 47 min drive from post. Open 24/7

Key

- Urgent Care
- Emergency Room
- Pharmacy
- Behavioral Health
- On post Ambulance
- Pediatric (Patient under 18 years old)

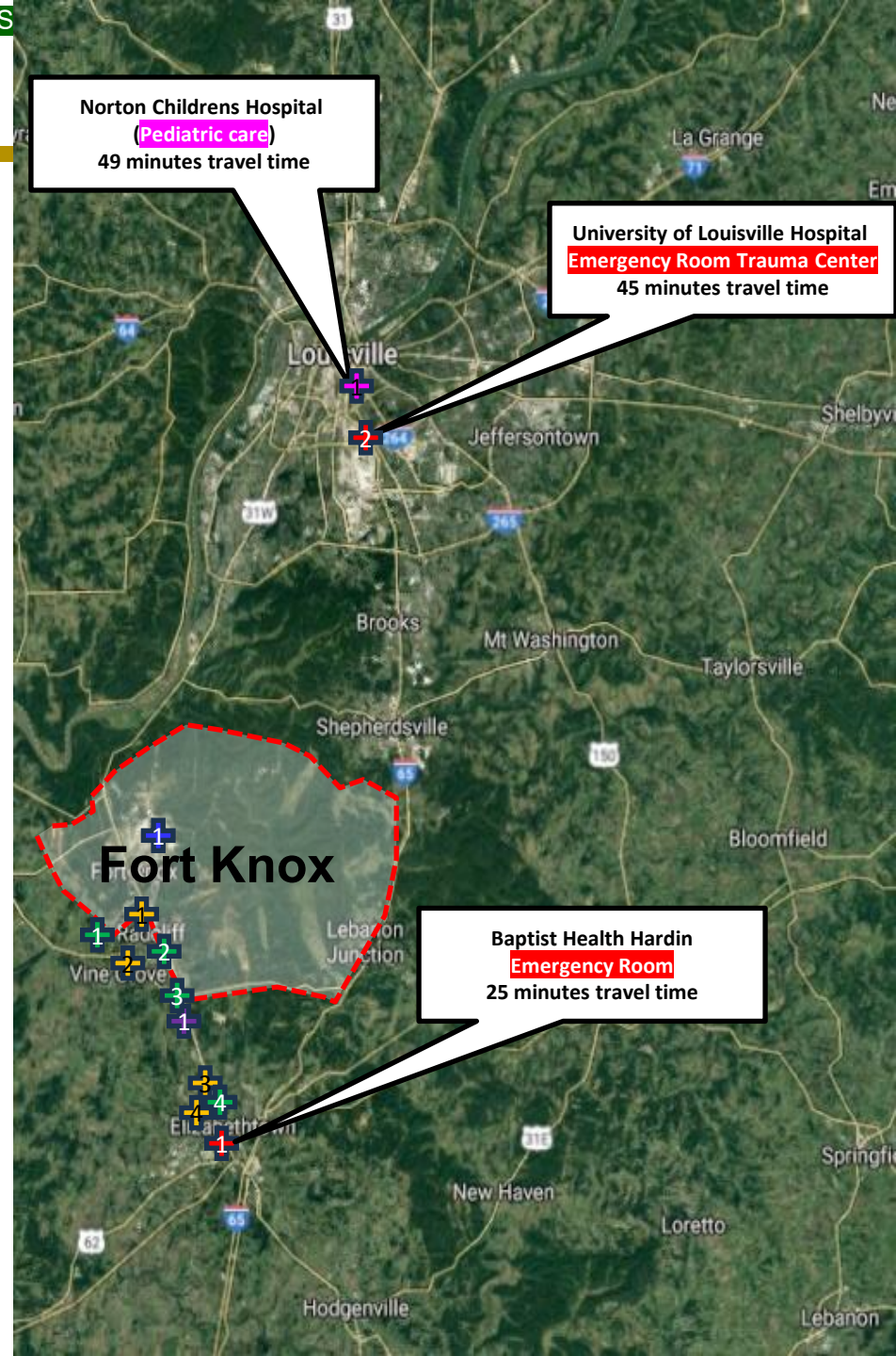



Leadership Excellence



Be All You Can Be

National Raider Challenge Competition

Hold Harmless Waiver



Leaders for Life



Hold Harmless Waiver pg. 1

Be All You Can Be

INDIVIDUAL RELEASE OF LIABILITY/HOLD HARMLESS AGREEMENT ("AGREEMENT")

PRIVACY ACT STATEMENT

This information is collected pursuant to 5 USC 301. The purpose of this information is to form a legally binding release agreement. The information will be used to evaluate and defend potential claims against individuals concerned and the United States Government. The information could ultimately be used in civil litigation and in the course of preparation for litigation. Supplying this information is voluntary; however, failure to provide the information could result in a denial of permission to participate in the events stated below.

I, the undersigned, acting in my own capacity and on behalf of myself, my heirs, children, wards, guardians, executors, administrators, subrogees and assigns and estate, under the authorities Army Regulation 145-2 grants the the Commanding Generals of U.S. Army Cadet Command and Fort Knox, Kentucky, while participating in the event(s) stated below, do hereby release the United States; U.S. Army; the Commanding Generals of U.S. Army Cadet Command and Fort Knox, Kentucky, and their officers, agents, and employees of and from any liability, claims, court actions, or causes of action for personal injury or property damage which I may suffer while participating in said events, during my transportation to and from the site, or while using facilities at Fort Knox. This release from liability covers any injury or damage resulting from my visit to Fort Knox to specifically include, but not be limited to, participation in those events.

Law Governing: The terms of this Agreement shall be governed and interpreted in accordance with the statutes and regulations of the United States, including but not limited to the regulations of the Department of Defense, Department of the Army, and U.S. Army Cadet Command, federal law, including but not limited to federal common law, and, when state law is incorporated as federal law, by the applicable laws of the Commonwealth of Kentucky.

Forum Selection: The parties agree that any dispute concerning participation in and/or claim and/or case (howsoever termed or denominated) arising from or pertaining to participation in the Raider Challenge and associated activities shall be brought before and resolved before the appropriate administrative and/or judicial forum in the Commonwealth of Kentucky, except to the extent applicable federal law vests subject matter jurisdiction in another forum.

Medical/Hospitalization Insurance: The Signatory to this Agreement represents that to the best of his or her knowledge he or she is covered by medical and hospitalization insurance or other financial assurance mechanism which will cover medical care and/or treatment and/or hospitalization and/or emergency medical transportation which may arise during the Raider Challenge event. The Signatory (and his or her Guardian(s) and/or parents) acknowledge that participation in the Raider Challenge and associated activities does not entitle the Signatory or any others to medical and/or hospitalization care, treatment and/or costs coverage at the cost and/or expense of the United States, Department of Defense, Department of the Army and/or U.S. Army Cadet Command.

Area of Activities: The Signatory to this Agreement acknowledges receipt of information which delineates the areal extent of the Raider Challenge and associated activities and that there is no invitation or permission extended to other areas, facilities and/or activities, and agrees to remain within said areal extent of the Raider Challenge and associated activities. This limitation does not apply to such person who has a right to visit and/or utilize other areas, facilities and/or activities such as military retirees, active duty and reserve component military service members, and their respective dependents. Should the Signatory wish to visit other areas, facilities and/or activities, he or she shall obtain a Temporary Visitors Pass at the Welcome Center before visiting such other areas, facilities and/or activities.

Hold Harmless Waiver pg. 2



Be All You Can Be

Waiver and Hold Harmless: The Signatory to this Agreement and his/her children, wards, guardians, heirs, executors, administrators, subrogees and assigns agree to and accept being allowed to participate in the Raider Challenge and associated activities in consideration for a full and complete release of any and all claims, demands, rights, and causes of action of any kind, whether known or unknown, including without limitation any claims for fees, costs, expenses, survival, or wrongful death, arising from and all known or unknown, foreseen or unforeseen bodily injuries, personal injuries, death, or damage to property, which they may have or hereafter acquire against the United States, its agencies, its agents, servants, or employees, on account of the subject matter of any administrative claim or suit, or that relate or pertain to or arise from, directly or indirectly, the participation in the Raider Challenge and associated activities. Each Signatory to the Agreement and his/her children, wards, guardians, heirs, executors, administrators, subrogees and assigns further agree to reimburse, indemnify, and hold harmless the United States, its agencies, its agents, servants, and employees, from and against any and all claims, demands, rights, and causes of action of any kind, whether known or unknown, including without limitation claims for subrogation, indemnity, contribution, or lien of any kind, or for fees, costs, expenses, survival or wrongful death that relate or pertain to or arise from, directly or indirectly, any act or omission that relates to the participation in the Raider Challenge and associated activities and/or being a spectator thereto.

I make this Individual Release of Liability/Hold Harmless Agreement voluntarily and realizing the consequences of said waiver and release.

PARTICIPANT NAME

EVENT(S):
RAIDER CHALLENGE 2025
AND ALL ASSOCIATED ACTIVITIES

PARTICIPANT SIGNATURE

PARENT/GUARDIAN NAME
(IF PARTICIPANT IS UNDER AGE OF 18)

DATE(S) OF EVENT:
O/A 23-26 OCTOBER 2025

PARENT/GUARDIAN SIGNATURE
(IF PARTICIPANT IS UNDER AGE OF 18)

LOCATION(S) OF EVENT:
A/N FORT KNOX, KENTUCKY

ADDRESS

CITY STATE ZIP

WITNESS NAME

WITNESS SIGNATURE

DATE



Leadership Excellence

Be All You Can Be

National Raider Challenge Competition

Media Release Waiver



Leaders for Life

Media Rights Waiver 1 of 2



Be All You Can Be

MEDIA CONSENT AND RELEASE WAIVER

PRIVACY ACT STATEMENT

This information is collected pursuant to 5 U.S.C. 301. The purpose of this information is to form a legally binding release agreement. The information will be used to evaluate and defend potential claims against individuals concerned and the United States Government. The information could ultimately be used in civil litigation and in the course of preparation for litigation. Supplying this information is voluntary; however, failure to provide the information could result in a denial of permission to participate in the events stated below.

I hereby certify that I am the adult parent and/or guardian of the undersigned minor child under the age of eighteen years. I, acting on behalf of my minor child, grant permission for the U.S. Army, U.S. Army Cadet Command (USACC), and Junior Reserve Officer Training Corps (JROTC), its successors, assigns, agents, and licensees, to use my photo and/or the photos of my child(ren) to promote USACC, JROTC, and the event listed below. I consent to the use of portraits, still or motion pictures of my or my child's appearance and/or recording of my or my child's voice. I consent to USACC and JROTC may use these photographs in both civilian and military news publications, with the knowledge that these publications may be distributed throughout the Army community, posted on the World Wide Web, used for commercial and advertising purposes. Any testimonial statements made by me, or my child may be included in publication, distribution, theatrical and television display, including without limitation to the Internet and any other electronic media, at the sole discretion of the U.S. Army, USACC, JROTC, its successors, assigns, agents, and licensees without limitation as to change, duration, or frequency.

I understand that neither my nor my child's biographical information will be used, in whole or in part, without further written consent as listed below.

I hereby waive the right to sue and/or lodge a complaint in any forum over the use of my photo and/or photos of my child(ren). I also waive the right to receive any compensation for the use of the photographs.

I am at least eighteen years of age and have carefully read and freely sign this Release Waiver Form (Minor Child). I understand and agree that no oral or written representations can or will alter the contents of this document.

Event(s):
Raider Challenge 2025
And All Associated Activities

Event Location:
Fort Knox, KY 40121

Participant Name:

Parent/Guardian Name:

Signature:

Date:

Address:

Phone Number:

Parent/Guardian Name:

Signature:

Date:

Address (If Different):

Phone Number (If Different):

Media Rights Waiver 2 of 2



Be All You Can Be

MEDIA CONSENT AND RELEASE WAIVER

PRIVACY ACT STATEMENT

This information is collected pursuant to 5 U.S.C. 301. The purpose of this information is to form a legally binding release agreement. The information will be used to evaluate and defend potential claims against individuals concerned and the United States Government. The information could ultimately be used in civil litigation and in the course of preparation for litigation. Supplying this information is voluntary; however, failure to provide the information could result in a denial of permission to participate in the events stated below.

BIOGRAPHICAL RELEASE

I agree to release the biographical information of _____ for use, in whole or in part, for use in publications, posted on the Internet and any other electronic media

Event(s):
Raider Challenge 2025
And All Associated Activities

Event Location:
Fort Knox, KY 40121

Participant Name:

Parent/Guardian Name:

Signature: _____

Date: _____

Address: _____

Phone Number:

Parent/Guardian Name:

Signature: _____

Date: _____

Address (If Different): _____

Phone Number (If Different):

National Raider Challenge Competition

Coaches Code of Conduct



Leaders for Life

Coaches Code of Conduct



Be All You Can Be



Coaches Code of Conduct Form

- Coaches have the professionalism, knowledge, experience, and preparation to lead their teams.
- Coaches are to always conform to the spirit and intent of applicable rules of the competition.
- Coaches are responsible for their own conduct as well as the conduct of their Cadets, assistant coaches/chaperones, and spectators.
- Coaches will accept final scoring outcomes and protest adjudications. They will not argue with or conduct themselves unprofessionally regardless of the results.
- Coaches accept that they do serve as role models and there must be congruency between their actions and words.
- Coaches actions contribute to a physically and emotionally safe environment for competition.
- Coaches exemplify the Army Values and sportsmanship regardless of the impact that might have upon the outcome of the competition.
- Coaches maintain a professional demeanor in their relationships with Cadets, Cadre, Lane Judges, Event OICs, brigade representatives, competing schools, and other event personnel, treat them with respect and dignity.
- Coaches are committed to the safety and well-being of each Cadet. Coaches follow current safety policy outlined in CCR 145-2 and USACC Annual Training Guidance Academic Year 24-25. Coaches will also ensure the 2300 NRC curfew is strictly enforced and adhered to.
- Coaches remember that competition should be healthy and enjoyable for all. I understand that I represent not only my team, school, and brigade but also USACC. I will conduct myself according to the standards presented in this Code of Conduct. I understand that the other coaches, Cadets, parents and USACC personnel will hold me accountable for the actions and behavior of myself as well as my Cadets, chaperones, and parents. I acknowledge that I am held accountable to this USACC Raider Challenge Code of Conduct and that failure to abide by the prescribed standards and expectations could negatively impact my team in the competition.

School: _____ Coach Signature _____

National Raider Challenge Competition

Cadet Packing List



Leaders for Life



Packing List



Be All You Can Be

Personal Gear

	Hydration System (Camelbak, Canteen or Water Bottle)
	Personal Identification (ID Card, Driver's License)
	Watch
	Personal Hygiene Kit
	Toothbrush
	Toothpaste
	Soap
	Deodorant
	Disposable or Reusable Razor
	Shaving Cream or Gel
	Comb or Hairbrush
	Hair Ties or Clips (if applicable)
	Feminine Hygiene Products (if applicable)
	Nail Clippers or Nail File
	Tissues or Toilet Paper
	Hand Sanitizer
	Sunscreen and Insect Repellent
	Hat or Cap for Sun Protection or Black Fleece Cap (Weather Dependent)
	Spare Clothing and Extra Socks
	Comfortable and Sturdy Footwear (Running Shoes and Issued Boots)
	Rain Jacket or Poncho
	Cold Weather Gear (Jacket, Hat and Gloves)
	Combination Lock
	Shower Shoes

Uniform and PT Gear (Cadet Uniforms Must Be Worn IAW CCR 145-2, Chapter 8)

	School Shirt
	OCP or ACU Top
	OCP or ACU Bottoms
	PT Gear (Shorts, T-Shirt, Shoes) School Shirt Authorized

Recommended Equipment for Course Preparation

	Good Attitude
	Rugged Notebook and Pen for Notetaking
	Eye Protection (Goggles, Sunglasses, or Approved Eye Protection)
	Gloves with Good Grip

Emergency Communication

	Personal Cell Phone for Emergency Contact
--	---

Event Registration and Documentation (Team Coach and Captain)

	Event Registration Confirmation and Paperwork
	MFR for Physical Requirements Met
	Signed Waiver Form (Signed by Parent if Cadet is Under 18 Years of Age)

Sleeping and Camping Gear: (Barracks will be available for Competitors)

	Pillow, linen, and Blanket for Barracks (ARMY WILL NOT ISSUE LINEN)
	Sleeping Bag
	Pillow
	Flashlight or Headlamp with spare batteries
	Tent or Shelter (if camping on-site)

BE SURE TO VISIT THE PATTON MUSEUM OF LEADERSHIP



Be All You Can Be



The official US Army Museum supporting Cadet Command. Over 30,000 sq ft of vehicles, weapons, and other artifacts on exhibit. Bus parking available. Gift shop on site.



**Open Tue-Fri 10AM-4PM Eastern Time
Open Saturday April 18 10AM-4PM for
National Raider Challenge.**

Directions:

Exit main post Fort Knox via the Chaffee Ave exit ramps or the main gate and head north toward Louisville on Highway 31W. The turn for the museum parking lot is next to a WWII Barracks building. Many GPS services do not give accurate directions to the museum.



**Scan QR Code for
Museum 31 W Gate
Location**



Be All You Can Be